



Cities Feeding People

CFP REPORT SERIES

Report 27

**Community-Based Technologies for Domestic Wastewater
Treatment and Reuse: options for urban agriculture**

by

Gregory D. Rose

Spring 1999

LIST OF TABLES.....	III
LIST OF FIGURES.....	III
EXECUTIVE SUMMARY.....	IV
PART I: SANITATION AND WASTEWATER RESOURCE RECOVERY.....	1
1.0 INTRODUCTION.....	1
1.1 ORGANISATION OF THE REPORT.....	1
1.2 TERM DEFINITIONS AND SCOPE OF THE REPORT.....	2
2.0 WASTEWATER MANAGEMENT.....	2
2.1 THE URBAN DILEMMA.....	2
2.2 COSTS OF (NOT) PROVIDING ADEQUATE SANITATION.....	3
2.3 URBAN AGRICULTURE AND WASTEWATER RESOURCES.....	5
3.0 PLANNING AND IMPLEMENTING WASTEWATER REUSE PROJECTS.....	6
3.1 APPROPRIATE TECHNOLOGY.....	6
3.2 MECHANISED VS. NON-MECHANISED WASTEWATER TREATMENT.....	7
3.3 ON-SITE SANITATION.....	8
3.4 DECENTRALISED URBAN CATCHMENT AREAS.....	9
4.0 PUBLIC HEALTH AND SAFETY.....	13
4.1 EFFLUENT QUALITY STANDARDS.....	13
4.2 HEALTH GUIDELINES.....	14
5.0 INSTITUTIONAL AND COMMUNITY RELATED ISSUES.....	16
6.0 SEGREGATING URBAN WASTEWATER RESOURCES.....	17
6.1 ISOLATION OF THE DOMESTIC WASTEWATER.....	17
6.2 INDUSTRIAL, MUNICIPAL AND DOMESTIC REUSE OF WASTEWATER.....	18
7.0 INTEGRATED RECOVERY.....	18
7.1 ECOLOGICAL ENGINEERING.....	19
7.2 ADVANCED SOLAR TECHNOLOGY.....	20
PART II: SELECTED TREATMENT TECHNOLOGIES.....	22
8.0 LAND-BASED TREATMENT TECHNOLOGIES.....	22
8.1 DRY VS. WET SANITATION SYSTEM.....	22
8.2 LAND-BASED, ON-SITE TREATMENT SYSTEMS.....	24
8.2.1 Double Vault Batch Composting Systems.....	24
8.2.2 Composting Toilets and Reed bed Filters.....	24
8.2.3 DAFF Latrines.....	27
8.3 ANAEROBIC TREATMENT SYSTEMS.....	28
8.3.1 Upflow Anaerobic filters.....	28
8.3.2 Biogas Reactors.....	29
8.3.3 Recent developments in biogas technology.....	31
8.4 OFF-SITE ANAEROBIC TREATMENT SYSTEMS.....	32
8.4.1 Upflow Anaerobic Sludge Blankets.....	32
8.5 SOIL AQUIFER TREATMENT.....	34
9.0 WATER-BASED WASTEWATER TREATMENT TECHNOLOGIES.....	34
9.1 ON-SITE WETLAND TREATMENT.....	34
9.2 OFF-SITE CONSTRUCTED WETLANDS.....	35
9.2.1 Subsurface Wetlands.....	36

9.2.2 Free Water Surface Wetlands.....	36
9.3 FLOATING AQUATIC MACROPHYTES.....	37
9.3.1 Water Hyacinth.....	37
9.3.2 Duckweed.....	38
9.3.3 Cropping system management.....	38
9.3.4 Disease vector management.....	39
9.4 DUCKWEED-BASED PISCI-CULTURE: PRISM-BANGLADESH.....	39
9.5 GREENGOLD CORPORATION.....	40
9.6 THE MAYSARA PROJECT.....	42
9.7 COMMUNITY-BASED WASTEWATER TREATMENT - CASTOR, SENEGAL.....	42
9.8 WASTEWATER STABILISATION PONDS.....	43
9.9 ADVANCED TREATMENT.....	44
9.10 RECENT ADVANCES IN WASTEWATER STABILISATION PONDS.....	44
9.10.1 Stabilisation ponds and supporting growth media.....	44
9.10.2 Advanced integrated ponds systems.....	45
9.10.3 Sheaffer modular reclamation and reuse system.....	45
9.11 AQUACULTURE.....	46
10.0 SLUDGE MANAGEMENT.....	48
10.1 SLUDGE REUSE IN EGYPTIAN AGRICULTURE.....	48
10.2 DEVELOPMENTS IN NATURAL SLUDGE DE-WATERING TECHNOLOGY.....	48
PART III: CONCLUSIONS AND RECOMMENDATIONS.....	50
11.0 CONCLUSIONS AND RECOMMENDATIONS.....	50
CONCLUSIONS:.....	50
RECOMMENDATIONS:.....	51
REFERENCES.....	54
ANNEX I - INTERNET RESOURCES.....	65
ANNEX II - REVIEWED PROJECTS IN WASTE MANAGEMENT (1974 - 1997).....	66
ANNEX III - TECHNOLOGICAL ADVANCES IDENTIFIED IN IDRC PROJECT REVIEW.....	71
ANNEX IV: REPORT CONTACTS.....	75

List of Tables

TABLE 2.1	NUTRIENTS IN HUMAN WASTE COMPARED TO NUTRIENTS IN FERTILISER.....	5
TABLE 3.1	DETAIL OF TECHNOLOGICAL OPTIONS REVIEWED.....	12
TABLE 4.1	GUIDELINES FOR TREATED WASTEWATER IN AGRICULTURAL IRRIGATION.....	15

List of Figures

FIGURE 3.5	ORGANISATION OF THE REPORT.....	11
FIGURE 5.1	RISK VS. VARIOUS CONTROL MEASURES.....	16
FIGURE 7.1	BIOGAS, SANITATION, AND PRODUCTION.....	19
FIGURE 8.1	DOUBLE VAULT LATRINE.....	25
FIGURE 8.2	CAROUSEL COMPOSTING TOILET.....	26
FIGURE 8.3	FISH NET BASKET COLLECTION LATRINE WITH ATTACHED WATER GARDEN?.....	27
FIGURE 8.4	UPFLOW ANAEROBIC FILTER.....	29
FIGURE 8.5	TYPICAL UASB CONSTRUCTION.....	34
FIGURE 9.1	CONFINED SPACE WASTEWATER TREATMENT SYSTEM.....	36
FIGURE 9.2	REED BED WASTEWATER TREATMENT DESIGN.....	37
FIGURE 9.3	DUCKWEED HARVEST.....	39
FIGURE 9.4	SITE PLAN: PRISM-BANGLADESH, MIRZAPUR.....	41
FIGURE 9.5	GREENGOLD: DUCKWEED-BASED WASTEWATER TREATMENT DESIGN.....	42
FIGURE 9.6	FISH HARVEST.....	47
FIGURE 9.7	RESOURCE RECOVERY & REUSE.....	48
FIGURE 10.1	REED BED DESIGN FOR FAECAL SLUDGE DEWATERING.....	50

Executive Summary

Urban environmental management is one of the most pressing issues as the urbanisation trend continues globally. Among the challenges faced by urban planners and managers is the need to ensure ongoing basic human services such as the provision of water and sanitation. The under-management of domestic wastewater in many southern urban areas presents a major challenge. The accumulation of human bio-waste is constant and unmanaged wastewater directly contributes to the contamination of locally available fresh water supplies. Additionally, the cumulative results of unmanaged wastewater can have broad degenerative effects on both public and ecosystem health.

The report explores the inadequacies in the provision of sanitation in the developing world. The replication of centralised, highly engineered human waste management systems resultant of sanitary reforms of the 20th century have not been successful in many developing world contexts. The report suggests that emergent trends in low-cost, decentralised naturally-based infrastructure and urban wastewater management that promotes the recovery and reuse of wastewater resources are increasingly relevant. The concept of managing urban wastewater flows at a decentralised or "intermediate" level, based on micro watersheds is explored. The report reveals how innovative and appropriate technologies can contribute to urban wastewater treatment and reuse and reviews the effluent treatment standards that are currently accepted in order to protect public health and safety. The concept of planning integrated wastewater management strategies in conjunction with an urban agricultural "waste-sink" is suggested as a rational approach to waste management and the conservation of valuable urban resources.

Urban waste management can and must be transformed from a disposal-based linear system to a recovery-based closed-loop system that promotes the conservation of water and nutrient resources and contributes to public health. Moreover, it is apparent from the literature that both the knowledge and the technology exist that can enable this transformation. There is a gap, however, between the current availability of innovative technology and the promotion/financing of demonstration level projects as well as the development of complementary socioeconomic methodologies to facilitate their implementation.

The report is comprised of a technology review and explores a series of wastewater treatment technologies that are low cost, potentially appropriate for urban environments and will enable the reuse of wastewater in agriculture production. Conventional and highly engineered waste management technologies and strategies often focus on electro-mechanical solutions that are capital intensive and require ongoing capital investments for effective operation. Additionally these systems have shorter life-cycles compared to many alternative and naturally-based technologies which also offer opportunities for resource recovery. This problem necessitates the need for sponsorship and funding of demonstration-level, self-help sanitation systems and treatment technologies that facilitate the reclamation and recycling of urban organic waste resources. Integrated organic waste recovery systems offer low-cost sanitation solutions and promote the recovery and reuse of valuable wastes for the benefit of a comprehensive environmental health.

Overall, the report aims to contribute to the ongoing development of low-cost options for the closed-loop recovery and reuse of organic waste resources in urban environments. The development of zero-discharge urban wastewater management strategies will contribute to a reduction in the pathogenic contamination of surface and groundwater and aid in protecting the vitality of urban dwellers. Organic waste recovery can result in production inputs for urban agriculture, enhance food security and link different sectors of local economies. De-centralised, organic waste recovery systems that integrate the best available low-technology are essential and appropriate components in the promotion of a comprehensive urban ecosystem health strategy.

Part I: Sanitation and Wastewater Resource Recovery

1.0 INTRODUCTION

The purpose of this report is to provide an overview of emergent trends in environmentally sound and economically viable approaches to wastewater management in the developing world. This report deals with the management of *domestic human waste* in the urban environment. The report focuses on alternatives to centralised electro-mechanical treatment technologies such as activated sludge facilities and offers an alternatives to sanitation systems dependent on large distance water-borne conveyance and high energy inputs for their operation. This aim of the report is to review recent developments in wastewater treatment and reuse that may contribute to public health, sanitation, the improvement of soil integrity and the conservation of fresh water resources.

Natural or naturally-based wastewater treatment technologies are defined in this report as those that employ natural processes (biological, physical or solar elements) to achieve a desired level of treatment. Naturally-based approaches are also defined in this paper as having one or more of the following characteristics:

1. achieving acceptable levels of treatment;
2. requiring low capital investment;
3. requiring low ongoing operation and maintenance costs;
4. requiring less skilled operator knowledge than many conventional technologies; and,
5. potentially having longer life-cycles than conventional electro-mechanical technology.

Therefore, several conventional treatment technologies (*e.g.*, activated sludge) would be considered a naturally based technology because treatment occurs biologically. However, this technology does not fit the definition entirely because of the need for high and ongoing energy inputs that make the technology expensive to operate and maintain.

The report will focus mainly on approaches or treatment technologies capable of three end goals:

- i) to reduce the pathogenic risk inherent to wastewater;
- ii) to facilitate the recovery of nutrient and water resources for reuse in agricultural production, the irrigation of municipal greenbelts, parks and maintenance of other landscape amenities, and;
- iii) to reduce the overall user-demand for water resources.

1.1 Organisation of the Report

The report is organised in the following manner. It is divided into three sections; a conceptual framework describing the organisation of the report is presented in chapter 3, *figure 3.5*.

- (A) **Problem Background and Emergent Themes;**
- (B) **Treatment & Recovery Options; and,**
- (C) **Conclusions & Recommendations.**

The *background section* discusses issues related to the planning and implementation of sanitation projects in urban and peri-urban environments. Public health, treatment guidelines, institutional aspects of implementing alternative schemes, and the emerging global paradigm in organic wastewater recovery and reuse are also discussed here. The *technology review section* breaks the technologies down into two distinct types, those that are land based and those that are water-based (*e.g.* soil aquifer infiltration treatment vs. constructed wetlands). The technologies are then further divided into those appropriate for on-site or off-site use. The *final section* of the report outlines the conclusions and recommendations generated from the literature review and associated international travel during the summer of 1998.

The report contains 4 annexes.

- ? *Annex I* is a recent list of organisations involved in some of the most innovative projects in the areas of sanitation and resource recovery. Of specific note is the *United Nations University - Zero Emissions Research Initiative (ZERI)* and the *Global Applied Research Network (GARNET)*.
- ? *Annex II* is a list the projects that have been reviewed during the internship by IDRC Centre file and name.
- ? *Annex III* lists seven projects receiving research funding from IDRC that were reviewed by the intern. The intern suggests that of the more than 100 projects in wastewater treatment that were reviewed, these 7 projects generated important outcomes and may potentially be built upon in the future.
- ? *Annex IV* is a list of contacts named in the report.

1.2 Term Definitions and Scope of the Report

Domestic human waste is defined in this paper as human excreta, urine, and the associated sludge (collectively blackwater), as well as, kitchen wastewater and wastewater generated through bathing (collectively known as greywater). The term *wastewater* will be used through the report to collectively define *domestic human waste*. Industrial wastewater is not encompassed in this definition of wastewater. Co-composting of solid organic waste and human faecal sludge is considered a viable approach to human waste management, and advances continue to be made in the development of suitable processes; however, co-composting processes will not be considered in this report either (Obeng and Wright, 1987; Lardinois and van de Klundert, 1993; Strauss, 1996).

2.0 WASTEWATER MANAGEMENT

2.1 The Urban Dilemma

In the year 2015 the majority of the global population (over 5 billion) will live in urban environments. At that time, there will be 23 mega-cities with a population of over 10 million each, 18 of which will exist in the developing world (Black, 1994; UN, 1997). Central to the urbanisation phenomena are the problems associated with providing municipal services and water sector infrastructure, including the provision of both fresh water resources and sanitation services. Currently, providing housing, health care, social services, and access to basic human needs infrastructure, such as clean water and the disposal of effluent, presents major challenges to engineers, planners and politicians (Black, 1994; Giles and Brown, 1997).

In developing countries, 300 million urban residents have no access to sanitation and it is mainly low-income urban dwellers who are affected by lack of sanitation infrastructure (Forget, 1992; Briscoe and Steer, 1993; Black, 1994; Veenestra and Alaerts, 1996; Giles and Brown, 1997). Approximately two thirds of the population in the developing world have no hygienic means of disposing of excreta and an even greater number lack adequate means of disposing of total wastewater (Sinnatamby, 1990; Niemczynowicz, 1996).

Unfortunately, the *International Water Decade* paid insufficient attention to the issue of sanitation and wastewater reuse in the developing world (Alaerts *et al.*, 1993). Although fresh water systems have been increasingly developed for the urban poor, urban drainage and sanitation systems have not been scaled-up proportionally; this has led to grossly unsanitary conditions that threaten the re-emergence of plague and pestilence in the developing world (WHO, 1987; Munasinghe, 1992; Black, 1994; Giles and Brown, 1997).

The 1992 UNCED Earth Summit and the resultant programme for action or Agenda 21, emphasised the urgency in addressing the urban environmental problems of pollution and environmental hazards endemic to urban areas of the developing world (Leitman, 1994; Alaerts *et al.*, 1993).

Agenda 21 outlined specific actions to promote environmentally sound urban waste management, including the maximisation of waste reuse and recycling (UNCED, 1992). However, Agenda 21 failed to highlight or promote specific waste reuse and recycling methods related to sanitation, and gave no indication as to the level of technology that would be most appropriate to pursue in the developing world (Sanchez, 1993; Otterpohl *et al.*, 1998).

Box 2.1 Global Human Waste Output

In 1950 the output of human waste (*i.e.* excrement and urine) was estimated to be 3.2 million tonnes; in the year 2000, the estimated daily output is expected to be 8.5 million tonnes per day or 3 billion tonnes per year.

Source: Fahm, 1980

Innovative approaches and new methodologies for protecting public health, recovering nutrient resources and protecting water resources from pollution are necessary (Asano and Levine, 1996; Harremöes, 1997; Sanio *et al.*, 1998). A resounding expression of the need for immediate action in the developing world has been made (Chan, 1996; Niemczynowicz, 1993, 1996). Integrated, zero-discharge, and wastewater reuse strategies are the emerging concept in municipal wastewater reuse at this time and the development and dissemination of viable alternatives for urban wastewater reuse is essential (Bouwer, 1993b; ICIBS, 1998).

2.2 Costs Of (Not) Providing Adequate Sanitation

Conventional conveyance and treatment infrastructure, engineered during 19th century sanitary reform has contributed to the high degree of sanitation and public health experienced in many cities today. Pathogenic waste is isolated and conveyed away from potential human contact and has decreased the threat of major epidemics of less than a century ago (Fahm, 1980; Angelakis *et al.*, 1995). This is not the case in most parts of the developing world. The problem in the developing world today, according to Black (1994), is that engineering solutions based on centralised systems built and maintained by subsidised public agencies are inappropriate to the extraordinary pace and character of the contemporary urbanisation process in the developing world.

The initial capital costs of providing effective sanitation services can be high. The approximate cost of constructing sanitation systems ranges from \$ 75-150 for a twin pit pour-flush latrine, to \$600-1,200 for a conventional sewerage system [1990 prices - US\$] (Hardroy and Satterthwaite, 1990). According to Grau (1994), countries with a per capita GNP of less than \$500 do not have the resources to construct treatment facilities and cannot maintain them (Niemczynowicz, 1996). Additionally, the water resources consumed in some sanitation systems can be very high. In the developing world, flush toilets can consume 20-40 percent of the domestic water resources used in a sewered city (Sanio *et al.*, 1998).

Preventing pollution through engineered solutions is often expensive and sometimes inappropriate depending on the context as these solutions often depend on high energy inputs, expert operator skills and continued maintenance expenditures (Edwards, 1985; Chan, 1996; Boller, 1997). The implementation of engineered solutions may also cause external and intangible ecological damage to adjacent ecosystems. Any benefits that may result are often to the advantage of a local region, but often to the disadvantage of the larger society or environment based on the cost of the solution and external impacts (*i.e.*, downstream impacts) (Yan and Ma, 1991; Munasinghe, 1992). The hygienic urban water supply, sewerage systems and many technologies of the last century are now in question with regards to their environmental efficiency and sustainability and new alternatives must be found (Niemczynowicz, 1993; Harremoes, 1997).

The human and socioeconomic costs of unmanaged and under-managed domestic waste are also very high (Munasinghe, 1992). In India, the 1994 plague epidemic resulted in a loss of tourism revenue estimated at \$US 200 million; in Peru, a recent cholera epidemic resulted in an estimated loss amounting to three times the expenditure on water and sanitation for the entire country over the preceding 10 years; and in Shanghai, China a recent major outbreak of hepatitis A was attributed to sewerage contamination (Munasinghe, 1992; Giles and Brown, 1997).

The economic benefits of reusing human wastes in agriculture can be realised at the farm level through supplementing the use of inorganic chemical fertilisers with reclaimed organic fertiliser derived from bio-waste (Sanio *et al.*, 1998). The benefits of reusing these organic wastes must also be measured against the cost of not doing so at both the economic and environmental level (Fahm, 1980; Gardner, 1998; Sanio *et al.*, 1998). Marine environment pollution is now global, and is of key concern to several governmental and non-governmental organisations (Ahmad, 1990; World Resource Institute *et al.*, 1996). Munasinghe (1992), has noted that World Bank data for the Eastern Mediterranean and North Africa region indicates serious aquatic pollution due to the failures to treat wastewater flows. Even the discharge of treated sewage presents a detrimental impact on coastal ecosystems and is a great loss of nutrient resources (Appasamy and Lundqvist, 1993). However, the costs of implementing zero-discharge organic waste to agriculture recycling schemes may not be expensive. Full-scale implementation of urban organic waste to agriculture systems could cost as little as US \$5 to \$6 million for a city of 1 million people (Sanio *et al.*, 1998).

2.3 Urban Agriculture and Wastewater Resources

According to Scott (1952:21), Winfield defined *Agricultural Sanitation* as "the successful sanitation of the environment of man and his domestic animals by means which are an integral part of sound agricultural practice". More recently, Otterpohl *et al.* (1998) defined sanitation as having two functions: i) to maintain the highest level of hygienic standards for humans and, ii) to keep soil fertile. The recycling of organic waste resources is just one aspect of a multi-dimensional and comprehensive approach to upgrading the quality of urban environments and protecting the environmental resources and aesthetic amenities of the hinterlands surrounding urban centres. Cointreau *et al.* (1984) have stated that sustainable resource recovery and utilization are essential elements of living within finite resources and that resource reuse must be economically justified. Urban Agriculture (UA) may provide that economic justification because producing food and fibre close to urban centres means jobs for people. More importantly, UA can provide the basis for effective wastewater management through providing a sustainable re-distribution of organic nutrients and soil conditioners for agricultural production in urban and peri-urban environments (UNDP, 1996; Gardner, 1998; Furedy, *et al.*, forthcoming).

Facilitating two-way organic waste nutrient cycles, from point-of-generation to point-of-production, closes the resource loop and provides a viable approach for the management of valuable wastewater resources (Gardner, 1998; Harsch, 1996; de Zeeuw, 1996; Otterpohl *et al.*, 1997;1998). Failing to recover organic wastewater from urban areas means a huge loss of life supporting resources that instead of being used in agriculture for food production, fill rivers with polluted water (Niemczynowicz, 1996).

Urban Agriculture draws on the often unmanaged and "un-recovered" urban waste stream inherent to a majority of cities in the developing world and attempts to re-direct these resources toward the production of food and fibre in an economically and environmentally sound fashion. Food production schemes can be augmented and enhanced by recycling human and animal waste if low-cost and reliable waste recovery technologies and approaches can be demonstrated and proven feasible (Chan, 1996).

One person can produce as much fertiliser as necessary for the food needs of one person (Niemczynowicz, 1997). However, the dilemmas posed by increasing global population and the corresponding production of primary human body waste, and its under management, are enormous. Safely recovering, and reusing human wastes as soil conditioner offers several benefits, including a reduction in effluents to receiving bodies, and the opportunity to re-build soil with valuable organic matter. This approach can also reduce the amount of chemical fertilisers imported by the developing world for food production (see table 2.1) (Gardner, 1998).

Table 2.1 Nutrients in Human Waste Compared to
Nutrients in Commercial Chemical Fertiliser (Mid 1990's)

<u>Country</u>	Nutrient Equivalent in Commercial Fertiliser Applied¹ (percent)
Kenya	136
Tunisia	25
Indonesia	49
Zimbabwe	38
Colombia	31
Mexico	31
South Africa	29
Egypt	28
India	26

¹ Assumes loss of 50% of nitrogen content to volatilisation.
Source: Worldwatch Institute (Gardner, 1998)¹.

3.0 PLANNING AND IMPLEMENTING WASTEWATER REUSE PROJECTS

3.1 Appropriate Technology

A functional and sustainable wastewater management scheme begins at the household level and is largely dependent on the “software” or the human component (Khouri *et al.*, 1994).

Only when perception of need, and perhaps, anticipation for a wastewater reuse system has been internalised at the community/user level, will planning and implementation be successfully executed (Khouri *et al.*, 1994). Local level support of a treatment and recovery scheme

can, in turn, catalyse pro-active institutions and vertical support from governments. Once the software component has been integrated into project development, the “hardware” or technological component can act to promote a comprehensive, integrated, and sustainable wastewater treatment and recovery strategy for the community - if it is well selected and “appropriate”. Several features characterise an appropriate wastewater treatment technology that can be a sustainable amenity to a community. Denny (1997) has stated that wastewater treatment technologies in the developing world must have one overriding criterion: the technology must be cost-effective and appropriate.

The following considerations should be made regarding the appropriateness of technologies:

- (1) the scheme or technology should be a felt priority in public or environmental health, and both centralised and de-centralised technologies should be considered (Veenstra and Alaerts, 1996);

Box 3.1 Technological Factors Leading to Failure

- ? in-appropriate and costly methods of collection and treatment;
- ? high-tech, large-scale, capital intensive, centralised treatment;
- ? irrational, water-borne, extensive sewer collection system.

Source: after Friins & Jansen. 1996

¹ Based on data from FAO, USAID, and U.S. Department of Commerce, and on Witter, E and J.M. Lopez-Real (1987).

- (2) the technology should be low-cost and require low energy input and mechanisation, which reduces the risk of malfunction (Frijns and Jansen, 1996; Boller, 1997);
- (3) the technology should be simple to operate, be "local" labour intensive, maintained by the community not rely on expensive chemical inputs, such as chlorine, for tertiary pathogen reductions to meet quality guidelines, and should be able to recover resources (Mara and Cairncross, 1989; Frijns and Jansen; 1996; Boller, 1997); and,
- (4) the technology should be capable of being incrementally upgraded as user demand or quality standards and treatment guidelines increase (Boller, 1997).

Public acceptance of reuse projects is vital to the overall future of wastewater reuse and the consequences of poor public perception could jeopardise future wastewater reuse projects (Asano and Levine, 1996). The selection of any treatment technology must be accompanied in advance by a detailed examination of the self-sufficiency and technological capacity of the community. The treatment alternatives must be manageable by the local community. Boller (1997) suggests that skilled operation and maintenance are essential to attain satisfactory performance and that technologies must require the lowest level of maintenance and control. The overriding criterion is that the system must be capable of achieving acceptable levels of pathogen reductions to facilitate the recovery of effluent for irrigation and organic soil amendment (Yu *et al.*, 1997).

3.2 Mechanised vs. Non-Mechanised Wastewater Treatment

Rapid urbanisation and industrialisation in many urban centres of the developing world pose major challenges to preserving water resources and the provision of sanitation. In India, like many developing nations, planning for domestic wastewater reuse is one area that has not received adequate attention, and to compound the problem, many existent treatment facilities are in poor repair (Chawathe and Kantawala, 1987). There are also cases where a mechanised waste management approach has replaced a low-tech solution, or traditional approach only to malfunction and cease to operate effectively (Lewcock, 1995).

Box 3.2 Mechanical vs. Natural Treatment Systems

"The discussion between mechanised or non-mechanised technologies relates to the locally or nationally available technological infrastructure which may ensure a regular supply of skilled labour, local manufacturing, operational and repair potential for used equipment, and reliability of supplies (power, chemicals spare parts etc.)."

Source: Veenstra & Alaerts, 1996: 35

Mechanised treatment systems (*e.g.*, activated sludge, trickling filter or rotating bio-contactors), are efficient, in terms of their spatial requirements (0.5-1 m² PE - compared to natural treatment systems at 5-10 m² PE), but depend on economies of scale to make them economically feasible (Veenstra and Alaerts, 1996). Electro-mechanical wastewater treatment technologies designed to remove high levels of biological oxygen demand (BOD) are not only huge capital investments, but also pose certain dilemmas if reuse of treated effluents is to be an option. Conventional, aerobic, treatment results in maximum reductions in BOD and nutrients while it is desirable to retain biomass BOD and nutrients for agricultural production (Bartone, 1991). Often, the removal of pathogens requires chemical inputs to meet disinfection guidelines, which increases the operation cost and complexity of the system. Dependence on chemical disinfection also complicates effluent reuse in non-restricted irrigation schemes when compared to low-cost solutions such as wastewater stabilisation ponds (WSPs), which are economical, produce similar reductions in BOD, nutrients, and greater pathogen reduction, but at a fraction of the cost (Veenstra and Alaerts, 1996; Mara and Pearson, 1998).

Highly engineered and mechanised conventional sewerage and wastewater treatment systems that require large capital investments, demand high maintenance costs, and are not feasible for the developing world (Cairncross and Feacham, 1993; Niemcynowicz, 1996; Edwards, 1996). Capital intensive and highly technological waste disposal solutions utilising indiscriminate collection and large-scale disposal, do not consider the value of recovering organic waste resources and do not promote “front-end” recycling or neighbourhood (local) reuse of organic waste (Cointreau, 1982; Gunnerson, 1982; Lardinois and van del Klundert, 1993).

3.3 On-site Sanitation

On-site sanitation has been accomplished through a variety of low-cost measures from bucket latrines to cess-pits, to composting toilets. Bucket latrines and manual collection systems are still in use today; however, in industrialising countries, such as India and China, are phasing-out manual collection and disposal methods (*i.e.*, the “conservancy system”) (Giles and Brown, 1997). In China, 0.3 million tonnes of nightsoil are produced daily and collected by more than 200 million people; in most cases the nightsoil is transported out of the city for use as fertiliser in land-based agriculture or fish production (Bo *et al.*, 1993).

On-site pit latrines and soak away pits are not a viable solution for high density urban areas as they depend on the permeability of soil and multiple systems can overload the infiltration capacity of the local strata (Alaerts, 1996; Giles and Brown, 1997). Septic tank systems and vault toilets are effective in containing wastes, providing they are properly lined, but require frequent servicing, depending on the size, and are often maximised in their capacity to the state of overflowing across streets and yards, thus contributing to non-point pollution sources. The cost to regularly service on-site septic systems is expensive. Consequently, regular servicing does not occur, and the function of the system becomes inefficient (Black, 1994). Another problem associated with septic tanks, is the number of vehicles needed to adequately maintain and service household-level tanks; the costs associated with the consumption of fossil fuels can be very high (Strauss, Heinss and Montangero, 1998).

Box 3.3 Factors Determining On-site or Off-site Sanitation

- (i) the availability of some kind of sewerage system;
- (ii) site-specific conditions with respect to the urbanisation pattern, population densities, soil permeability and stability, and the existing service levels for infrastructural facilities like water;
- (iii) environmental considerations with respect to ground water or surface water pollution and their public health impacts;
- (iv) institutional requirements to allow proper matching of the responsibilities for operating, maintaining, financing, and care taking among government, community, and third parties;
- (v) sociocultural and socioeconomic constraints and opportunities that define the potential for community involvement in construction, operation and maintenance, and for cost recovery; and,
- (vi) economic and financial cost analysis.

source: Alaerts *et al.*, 1993: 180

3.4 Decentralised Urban Catchment Areas

Conveyance and treatment in sanitation planning have been approached in two ways: *on-site sanitation* at the household level and *off-site sanitation* at the city level (Alaerts *et al.*, 1993). Numerous problems exist in providing effective wastewater collection and treatment systems to dense, highly populated urban areas (Giles and Brown, 1997). Many areas inhabited by the urban poor, especially squatter settlements, are found on marginal land, (*i.e.*, marshes, and steep rocky hillsides) that are difficult to excavate for the implementation of water-borne sewage schemes (Giles and Brown, 1997). Several options have recently been proposed and appear feasible, but necessitate further development.

Alaerts *et al.* (1993) have discussed an "intermediate" level wastewater management scheme. Intermediate not referring to the technical level or appropriateness of technology, but intermediate in terms of conveyance distance between point of waste generation and the point of treatment. This approach would allow for wastewater management to be broken down to the neighbourhood or community level and to serve disaggregates of the larger urban areas. Selection of technology could be made based upon specific site conditions and financial resources of individual communities. Technology could be more easily matched to segregate and/or recover individual resources of the waste stream - including the industrial waste stream (Veenstra and Alaerts, 1996).

Box 3.4 Intermediate Scale Sanitation

"An intermediate-scale sanitation opens new perspective and may be more cost effective in less-industrialised countries; it aims at pre-treatment at on-site level for a number of households ("shared" treatment) or for a township ("communal"), followed by transportation through cheaper shallow sewers or open drainage networks to a central place outside the city to allow for final treatment and disposal."

source: Alaerts *et al.*, 1993: 180

Promoting the development of decentralised wastewater treatment and recovery technologies that are linked with urban agriculture systems, at the neighbourhood level, appear to be a rational approach to solving the human and environmental health dilemmas that result from under-managed wastewater. Decentralised, small-scale systems must be considered in planning and upgrading urban environments (Chan, 1996; Veenstra and Alaerts, 1996). Gravity flow, small bore sewerage, and water borne conveyance systems offer the potential to decentralise urban environments into catchment systems, each with their own integrated treatment plant and at low costs (Alaerts *et al.* 1993; Mara, 1996; Chan, 1996). These systems could be based on the topography of the local watershed, opposed to sector or citywide collection and treatment schemes, and would result in small-scale facilities equally dispersed through the urban environment. Pathogen reduction and nutrient recovery would occur through the use of integrated biological processes, which are also low-cost. This approach would allow for independent, self-maintained, and self-sustained facilities that are capable of recovering wastewater resources and immediately reusing them in decentralised urban farms (Chan, 1996).

In many situations, on-site treatment and storage systems (*e.g.*, anaerobic treatment technologies and septic tanks) can be effectively used for the management of wastewater, but they require periodic emptying and the sludge must be transported to agro-production units. In this case, technologies such as the MAPET may be feasible to promote the decentralised treatment scenario. The MAPET (Manual Pit Latrine Emptying Technology) was developed by WASTE Consultants to facilitate the emptying of pit latrines in low-income, unplanned areas of Dar es Salaam (Muller and Rijnsburger, 1994). The MAPET pump is manufactured locally in Tanzania. The unit is mounted on two pushcarts and is much more hygienic for workers than the previous practice of manually emptying latrine sludge because direct contact between the worker and the sludge is reduced (Muller and Rijnsburger, 1994). Combining this type of innovative sludge removal technology with decentralised, household or community level treatment systems that can be directly integrated with agriculture is an area that warrants further exploration.

Planning decentralised, intermediate distance treatment facilities in combination with urban agriculture at the corresponding level would allow for the assimilation of wastewater resources and would equally disperse them within urban areas. This strategy would reduce the distance that wastewater is conveyed and would eliminate the need to discharge to receiving bodies. Furthermore, it would reduce the amount of sludge disposed to landfill sites (Strauss, 1996). Bower (1993b) has noted that increasingly, small satellite plants are being built to provide reclaimed waste for local use.

If small-scale, easily maintained and operated single or multi-residence treatment systems, providing maximum levels of environmental health and public safety can be developed and easily replicated, then institutional resources can be directed toward education supporting their dissemination and incremental upgrading. National, mid-level, and municipal policies must be action-oriented and support institutional environments that favour the adoption of innovative technologies, otherwise, they are destined to failure.

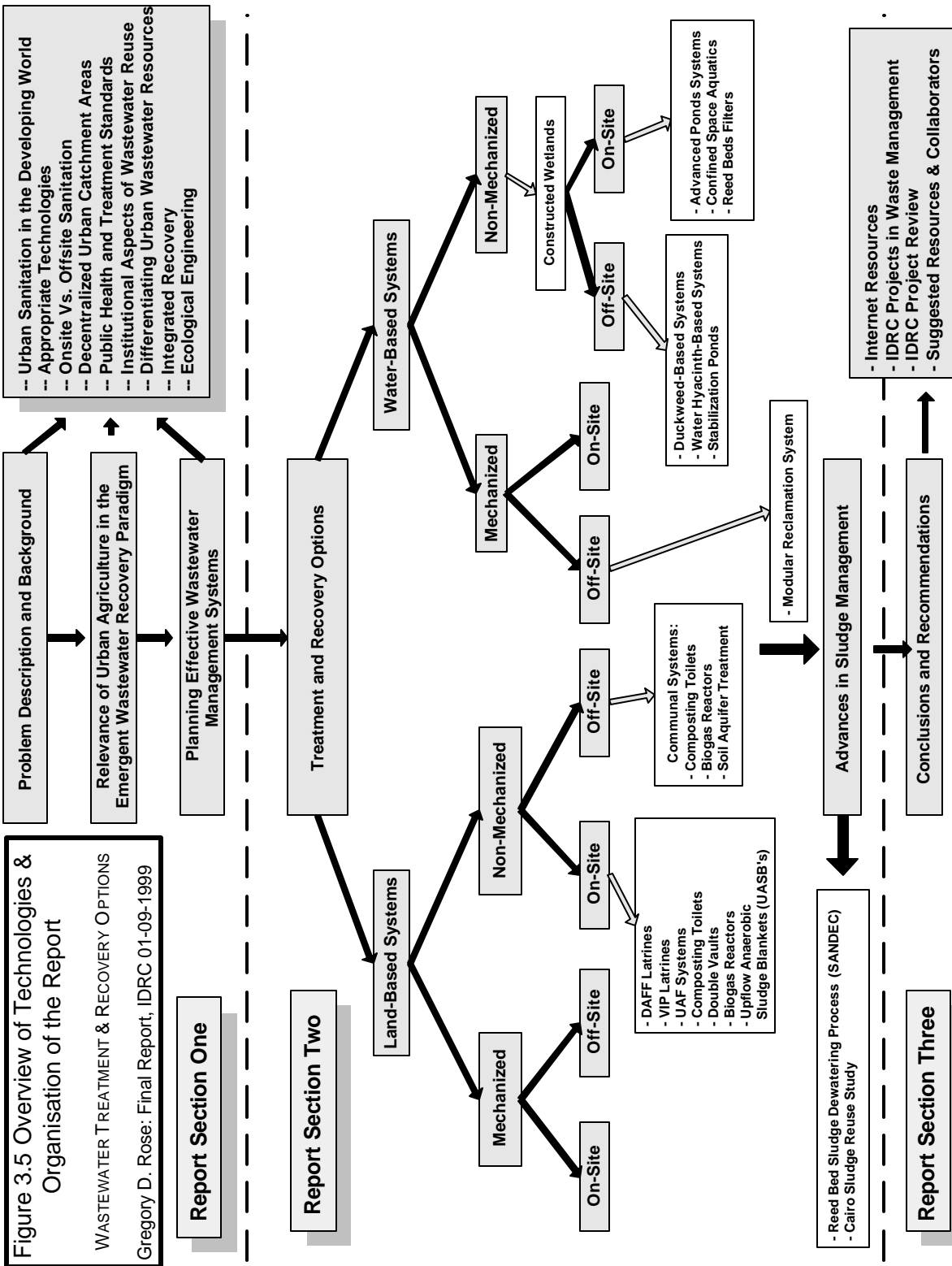

Table 3.1 Detail of Technological Options Reviewed	
LAND-BASED SYSTEMS TREATMENT	
Onsite Treatment Options	
<p>Composting Toilets</p> <p>Reed bed Filter Combinations Double Vault Batch Systems DAFF Latrines</p> <p>report section 8.2.2</p>	<p>Pro's: Decentralised; no energy input; waterless; low cost; eliminate need for community-level sewerage systems; proper use and length of decomposition enables near total pathogen reduction; produces compost for use in agricultural production; able to assimilate greywater flows from households; potentially capable of producing agricultural forage.</p> <p>Con's: User involvement necessary for proper maintenance; the production of compost must be paralleled by an agricultural waste "sink" for correct management of the bio-waste.</p>
<p>Upflow Anaerobic Filters</p> <p>report section 9.3.1</p>	<p>Pro's: Promote a decentralised, on-site wastewater collection and treatment; simple to construct and to operate.</p> <p>Con's: Requires further research and testing in the urban context.</p>
<p>Biogas Reactors</p> <p>report section 8.3.2</p>	<p>Pro's: Well demonstrated at this time; no energy input; capable of destroying wastewater pathogens; capable of producing energy in the form of methane for cooking and lighting and to run water pumps; electrical generators etc.; treated slurry can be used in agricultural production.</p> <p>Con's: Operation requires a certain level of operator knowledge for efficient and ongoing function; numerous designs exist and efficient operation may depend on the selection and optimisation of locally available materials and site specific design needs.</p>
Offsite Treatment Options	
<p>Upflow Anaerobic Sludge Blankets</p> <p>report section 8.3.1</p>	<p>Pro's: Requires low external energy input; high organic removal efficiencies; simple to operate; low capital costs (depending on scale); low ongoing operation and maintenance costs; low land requirements; low sludge production.</p> <p>Con's: Not considered effective in total pathogen removal and sludge must undergo further treatment.</p>
<p>Communal Composting Toilet Systems</p>	<p>Pro's: Treatment is biological and requires no external energy input; able to serve larger numbers of users than family sized home-based units; potentially easier to maintain and to recover compost for agro-production operations.</p> <p>Con's: Moderate to high maintenance and user involvement necessary.</p>
<p>Soil Aquifer Treatment</p> <p>report section 8.5</p>	<p>Pro's: Estimated to be less expensive than electro-mechanical treatment options; pathogen removal surpasses secondary treatment; is not considered highly technical; may promote reuse of wastewater where sociocultural taboos conflict with wastewater reuse.</p> <p>Con's: Requires electrical power consumption to pump and withdraw untreated and treated effluent; probably not feasible for urban wastewater treatment schemes.</p>
WATER-BASED TREATMENT SYSTEMS	
Onsite Treatment Options	

<p>Confined Space Aquatic Systems</p> <p>report section 9.1</p>	<p>Pro's: No external energy input required; operates in a confined space environment; units can be constructed to serve disaggregated populations in urban environments; produces a forage and can be integrated with small-scale animal production schemes.</p> <p>Con's: System requires further development and demonstration.</p>
Offsite Treatment Options	
<p>Constructed Wetland Systems (subsurface and free water surface)</p> <p>report section 9.2</p>	<p>Pro's: No external energy input; effective in the removal of BOD; TSS and nitrogen; low maintenance requirements; availability of local materials can reduce construction costs; system can produce value-added agricultural products; production of forage offers low costs alternatives for secondary and tertiary treatment in combinations with primary treatment technologies such as stabilisation lagoons.</p> <p>Con's: Controversy noted in the literature regarding the efficiency of constructed wetlands for primary treatment.</p>
<p>Advanced Integrated Pond Systems</p> <p>report section 9.10.2</p>	<p>Pro's: External electrical energy required, high treatment efficiencies reported; potentially long system life-cycle when large scale systems implemented; treated effluent is made available for irrigation; operation is simple.</p> <p>Con's: Requires further research and testing in the urban context; spatial requirements are smaller than conventional wastewater stabilisation ponds.</p>
<p>Wastewater Stabilisation Ponds</p> <p>report section 9.8</p>	<p>Pro's: No external energy required for actual treatment depending on design; considered the lowest cost wastewater treatment option available when land costs are low; operation is simple; coliform reduction approaches 99.999% and 100% helminth removal; operate well in tropical environments.</p> <p>Con's: Large land requirements are necessary.</p>

4.0 PUBLIC HEALTH and SAFETY

4.1 Effluent Quality Standards

As water demand and technologies improve, it is likely that wastewater reuse will continue to expand in the future (Asano and Levine, 1996). This is especially true in the Mediterranean basin countries of North Africa, the Middle East, and Southern Europe where wastewater reuse for farming has always existed (Bahri and Brissaud, 1996). The most critical issues regarding reclaimed wastewater is the protection of public health. Unlike fresh water irrigation, reclaimed wastewater is restricted to certain uses due to public health or water quality concerns (Asano *et al.*, 1996; Mills and Asano, 1996).

The effectiveness of any treatment technology must be directly correlated to the end-use and the associated water requirements (Bouwer, 1991; Asano and Levine, 1996). The recovery and reuse of wastewater and protection of public health are achieved through following a control algorithm that includes: (1) wastewater **treatment** to reduce pathogen concentrations to meet the WHO (1989) guidelines; (2) crop **restrictions** to prevent direct exposure to those consuming uncooked crops; (3) **application methods** (*irrigation*) reducing the contact of wastewater with edible crops; and, (4) human **exposure control** for workers, crop-handlers and final consumers (WHO, 1989; Mara and Cairncross, 1989; Strauss and Blumenthal, 1990).

4.2 Health Guidelines

The most recent guidelines directing the reuse of wastewater to a level considered safe to protect human health are those outlined in the *Engelberg Standards*, later adopted as the WHO (1989) "*Health Guidelines for the Use of Wastewater in Agriculture and Aquaculture*". These guidelines outline microbial quality guidelines for treated wastewater for use in restricted and unrestricted irrigation (see *figure 5.1*) (IRCWD, 1985; Mara and Cairncross, 1989; Khouri *et al.* 1994).

Restricted irrigation refers to the irrigation of crops not directly consumed by humans (*e.g.*, trees, fodder crops). For restricted irrigation, wastewater effluent must contain ≤ 1 viable intestinal nematode egg per litre, implying a > than 99% treatment level. This guideline has been introduced to protect the health of field workers and to indirectly protect consumers and grazing cattle (beef tapeworm) (Mara and Cairncross, 1989). Unrestricted irrigation refers to the irrigation of vegetable crops eaten directly by humans, including those eaten raw, and also to the irrigation of sports fields, public parks, hotel lawns, and tourist areas (Mara and Cairncross, 1989). The criteria for unrestricted irrigation, contains the same helminth criteria as restricted irrigation, in addition to a restriction of no more than a geometric mean concentration of ≤ 1000 faecal coliforms per 100 ml/treated effluent. These guidelines have been introduced to directly protect the health of consumers who may eat uncooked crops such as vegetables and salads (Mara and Cairncross, 1989).

Table 4.1 Guidelines for Treated Wastewater in Agricultural Irrigation (Adopted by WHO 1989)

Reuse Process	Intestinal nematodes ^a (Arithmetic mean no. of eggs per litre)	Faecal coliforms (geometric mean no. per 100 ml.)
<u>Restricted Irrigation</u> ^b (Irrigation of trees, industrial crops, fodder crops, fruit trees ^c and pasture ^d)	≤ 1	Not applicable
<u>Unrestricted irrigation</u> (Irrigation of edible crops, sports, fields, and public parks ^e)	≤ 1	≤ 1000 ^f

^a Ascaris, Trichuris and hookworms.

^b A minimum degree of treatment equivalent to at least a 1-day anaerobic pond followed by a 5-day facultative pond or its equivalent is required in all cases.

^c Irrigation should cease two weeks before fruit is picked, and no fruit should be picked off the ground.

^d Irrigation should cease two weeks before animals are allowed to graze.

^e Local epidemiological factors may require a more stringent standard for public lawns, especially hotel lawns in tourist areas.

^f When edible crops are always consumed well cooked, this recommendation may be less stringent.

Source: International Reference Centre for Waste Disposal (1985), in Mara and Cairncross (1989)

The standards are expected to be achievable with simple, inexpensive treatment methods that are appropriate for the developing world (Khouri *et al.*, 1994). The guidelines aim to prevent disease transmission while facilitating the recovery and reuse of resources (Mara and Cairncross, 1989). The WHO (1989) guidelines offer a starting point for wastewater reuse efforts. These guidelines are widely accepted and should offer public health protection if they are applied (Bartone, 1991; Khouri *et al.*, 1994). In countries where agricultural exportation is possible, higher standards than the WHO guidelines may be considered. Shelef and Azov (1996) have noted that where the reuse of wastewater irrigation is practised or planned, such as in the exportation of agricultural crops for economic development, the WHO (1989) quality criteria are considered too lenient and higher standards such as those promulgated by the U.S. Environmental Protection Agency (1992) and the Israel Ministry of Health (1978) are often followed. This should be noted where the international export of agricultural products is expected to occur.

Figure 5.1 Risk vs. Various Control Measures

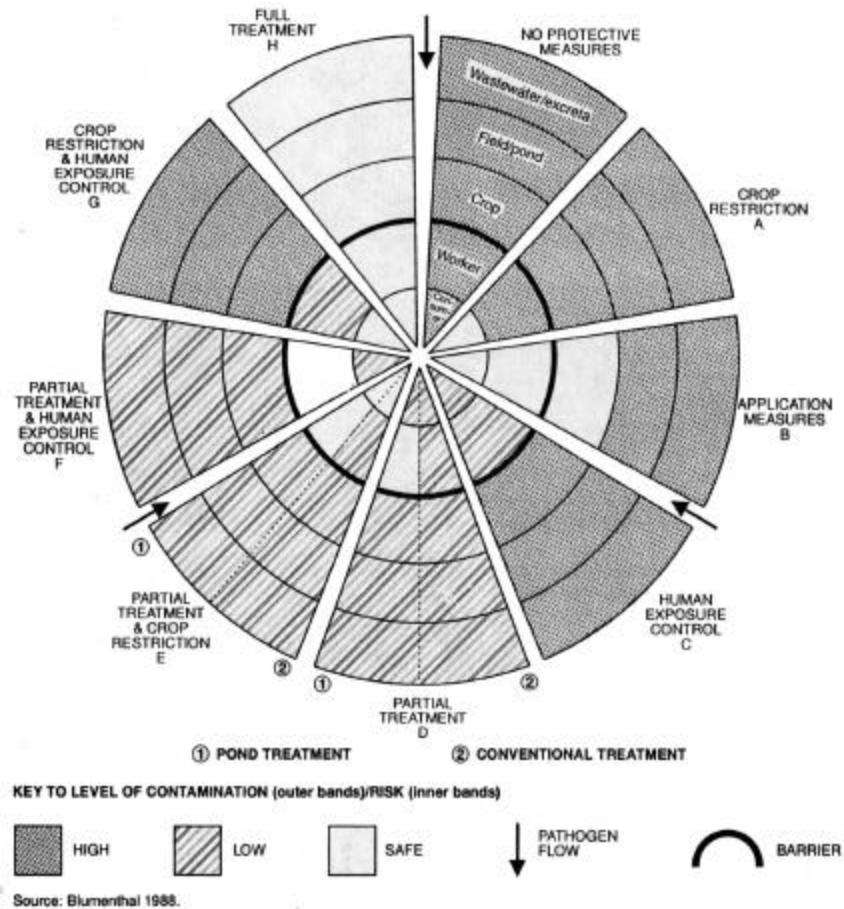

"Generalized Model of the level of risk to human health associated with different combinations of control measures for the use of wastewater or excreta in agriculture or aquaculture. The concentric circles (bands) represent the various "media" on the path of human pathogens from point of wastewater effluent disposal to the potential consumer of contaminated foods. The effect of different remedial techniques (interventions A to H) in protecting agriculture workers and consumers is shown and compared to the high contamination risk associated with the (nonrecommended) practice of reusing untreated wastewater for irrigation."

Blumenthal (1988) in Khouri *et al.*, (1994): 11.

5.0 INSTITUTIONAL and COMMUNITY RELATED ISSUES

Institutional and social dimensions cannot be overlooked in the implementation of resource conserving alternative wastewater technologies. The adoption of an alternative technology corresponds directly to the level of acceptance it gains from both the household user and the institutional framework from which the technology is supported and developed (Frijns and Jansen, 1996; Khouri *et al.*, 1994; Veenstra and Alaerts, 1996). Frijns and Jansen (1996) have pointed out that although alternative technologies may be less expensive per capita, they often require community “investment” efforts and resources from residents. However, decentralised, alternative sanitation strategies also offer the opportunity to extend services in an incremental fashion. Marks (1993) has noted that incremental sanitation schemes encourage self-help wherever possible.

Partnerships among community level users, private sector contractors and government officials must be equitable and pre-determined. Community ownership and participation are essential components for the implementation and success of any large-scale project - centralised or decentralised. Frijns and Jansen (1996) have pointed out that an institutional framework should guide responsibilities among stakeholders. If greater private sector involvement evolves out of this model, it is necessary to pre-determine the roles and responsibilities of each party. Elmendorf (1992) noted that the implementation of decentralised sanitation systems, particularly those that prove self-sustaining and perhaps generate income through sale of reclaimed resources, may threaten government officials, contractors and local leaders who may fear a loss of jobs, money or patronage. Friction can potentially develop in the community, and it is; therefore, advisable that an attempt be made to include a broad cross-section of community groups and public and private organisations. Whether the wastewater treatment system is biological or mechanical, on-site or intermediate-level off-site, collaboration and rewards, both economic and environmental, can be realised if strong collaborative relationships can be developed among the community, the construction and servicing groups (or community maintenance members), and supporting institutions.

In Rufisque, Senegal, success of a locally developed ecological wastewater purification system using water hyacinth/water lettuce (*pistia stratiotes*) has resulted in multiplier effects. Maintenance and operation staff have been able to gain skills allowing them to assist other districts and towns in upgrading their services (Malick and Diallo, 1997). Dissemination of this locally managed and low-cost sanitation technology has stimulated a growth sector of the local economy while increasing public awareness of the issue and improving the environmental health of the community.

6.0 SEGREGATING URBAN WASTEWATER RESOURCES

6.1 Isolation of the Domestic Wastewater

Wastewater-related diseases can be divided into those caused by chemical substances such as heavy metals and other toxins in mismanaged industrial effluent, and those caused by biological agents or pathogens (Giles and Brown, 1997). Both chemical substances and biological pathogens are a threat to public health as they can be transferred up the food chain when contaminated wastewater is used to irrigate crops or used in aquaculture (Furedy *et al.* forthcoming; Beck *et al.*, 1994; Asano and Levine, 1996; Bartone, 1991). It is suggested that industrial pollution may pose an even greater risk to public health than pathogenic organisms (Edwards, 1996). Therefore, increasing emphasis is being placed on the need to separate the domestic and industrial waste stream in order to differentiate urban waste resources and to treat them individually for ease of recovery and reuse (Otterpohl *et al.*, 1997, 1998; Niemczynowicz, 1993). Approaches must be found to isolate industrial toxins, pathogens, carbon, and nutrients if future societies are to be sustainable (Niemczynowicz, 1993).

As Gardner (1998) has stated:

“Recycling human waste safely and effectively will require different technologies, or different ways of using existing ones. Sewers, for example, often contaminate human waste with heavy metals or toxic chemicals from industry or households. Conventional treatment plants remove nutrients (and other matter) from wastewater, which lowers the enrichment level of effluent used for irrigation. And conventional treatment methods (with the exception disaffection, which is rarely practised in developing countries) reduce pathogens by too little for safe reuse in agriculture. Thus, many of today's disposal technologies are not well suited to producing fertiliser products” (Gardner, 1998: 105).

In turn, strategies and technologies can be implemented to treat and recover wastewater resource for food production systems that are close to urban centres. Overall, this will decrease transportation costs of moving food in, and waste out, of urban centres. Corresponding to this shift will be a reduction in the amount of chemical fertiliser inputs that are needed to sustain adequate levels of food production.

Otterpohl *et al.* (1998) have stated that the central issue regarding centralised vs. decentralised sanitation systems is not a question of structure, but rather a question of mixing different qualities of urban resources.

They have also stated that the centralised approach leads to:

- (1) the contamination of downstream receiving bodies, which poses an acute public health hazard- especially in developing countries where treatment efficiency may not be high;
- (2) the loss of nutrient resources (N)(P)(K) and (S) and trace nutrients inherent to domestic waste, and loss of opportunity to maintain the fertility of soil through recovery and reuse, thereby, perpetuating the need for producers to purchase inorganic fossil fertiliser; and,
- (3) the mixing domestic waste with industrial wastewater, which results in a contaminated sludge that is not valuable as a fertiliser for use in agricultural production.

The industrial wastewater stream must be segregated from the domestic wastewater stream in order to utilise the nutrient and trace elements for soil conditioning and food production. Otterpohl *et al.* (1998) have stated that sanitation and waste management should be primarily concerned with the maintenance and improvement of fertile soil and that future sanitation designs must aim for this goal. They state that traditional sanitation systems solve acute pollution problems, require relatively small treatment capacities per inhabitant, and can be economical, providing conveyance distances are short, but that the central problem occurs with the mixing of different qualities of waste resources. The reuse of wastewater can be curtailed for irrigation or aquaculture when industrial wastewater is discharged into sewers (Khouri *et al.*, 1994).

6.2 Industrial, Municipal and Domestic Reuse of Wastewater

Municipal uses of treated wastewater include the irrigation of road plantings, parks, playgrounds, golf courses, and toilet flushing etc. (Bouwer, 1993a). Industrial reuses of wastewater include cooling systems, agricultural uses (irrigation and aquaculture), the food processing industry and other high-rate water uses (Bouwer, 1993b; Khouri *et al.* 1994; Asano and Levine, 1996). In Middle Eastern countries, where water is scarce, dual distribution systems will, in the near future, provide high quality treated effluents for toilet flushing to hotels, office buildings, etc. (Shelef and Azov, 1996).

In India, wastewater is currently being used for irrigation, gardening, flushing, cooling of air conditioning systems, as a feed for boilers, and as process water for industries (Chawathe and Kantawala, 1987). In China, national policy has been developed that promotes the development of water efficient technologies, and encourages the reuse of reclaimed municipal wastewater in agriculture first, and then for industrial and municipal uses (Zhongxiang and Yi, 1991). In Japan, reclaimed wastewater is used for toilet flushing, industry, stream restoration and flow augmentation to create "urban amenities" such as green space (Asano, Maeda, Takaki, 1996).

7.0 INTEGRATED RECOVERY

During the early 1980s, the Tokyo branch of the United Nations University conducted a special study on ecological engineering and integrated farming systems in China (Chan, 1993). Interest in these systems has been renewed. Recently, the Integrated Bio-Systems conference, jointly organised by the *Institute of Advanced Studies* (IAS) of the United Nations University (UNU-Tokyo) and the UNESCO *Microbial Resource Centre* at Stockholm, as an activity of the UNU/Project *Zero Emissions Research Initiative*, focused on the recovery and reuse of biological waste.

Some of the more salient examples and topics to arise during the conference related to how ecological engineering is being used in the conservation of natural resources and in the production of primary agricultural products. Ecological engineering integrates organic waste management strategies to improve the integrity and productivity of soils for food production. Numerous case studies were presented which provided examples for small-scale sewage wastewater treatment systems for production of crops and livestock in multiple-products systems based on the recovery and reuse of organic waste (Foo and Della Senta, 1998).

7.1 Ecological Engineering

Ecological engineering has emerged as a field with the potential to conserve the natural environment while at the same time adapting to and solving sometimes intractable environmental pollution problems (Mitsch and Jorgensen, 1989). Todd and Josephson (1996) have stated that ecological engineering will influence the future of waste treatment, environmental restoration and remediation, food production, fuel generation, architecture, and the design of human settlements. Wang *et al.*, (1998) and Qixing *et al.*, (1996) have stated that the systematic planning of wastewater reuse schemes employing a combination of technology, (e.g., anaerobic reactor systems and constructed wetlands) for food and fibre production, may offer one solution to solving food shortages and water pollution.

Yan and Ma (1991) have described the benefits of ecological engineering in contrast to other approaches, such as environmental engineering and mechanised treatment systems, as a method to produce environmental, ecological, economic and social benefits not only in the locality of the intervention, but with benefits extending to the larger society and the environment as well. In terms of domestic

wastewater treatment, Ma and Yan (1989) have stated that ecological engineering can have the highest economic benefits in wastewater treatment because it does not depend on high operation and maintenance costs and involves the regeneration of abandoned resources (Mitsch, 1991). The goal of ecological engineering is to attain high environmental quality, high yields in food and fibre, low consumption, good quality, high efficiency production and full utilisation of wastes. This is in clear contrast to the mono-objectives of "environmental engineering" where mitigation or remediation are the goals and mechanised components, such as scrubbers, filters, settling tanks and precipitators, are used (Yan and Ma, 1991; Mitsch, 1991; Chan, 1993).

China is one developing country that has made major advances in optimising approaches to recovering and reusing primary human and animal waste products to maximise production. Historically, China and Asia have always treated wastes as valuable resources - wastes are consistently returned to the environment to replenish earlier removal (Chan, 1993). The Chinese government has supported the emerging practice of ecological engineering that combines waste management with livestock rearing, aquaculture, agriculture and agro-industry, and uses locally-available natural resources in ecologically balanced systems for food production (Chan, 1993). Admittedly, sustainable traditions in China are under increasing pressure from industrialisation and urbanisation. However, as late as 1998, it appears that the Chinese government is actively promoting the efficient reuse of waste resources in integrated production systems such as aqua-culture (Wang *et al.*, 1998). Currently, there are more than 2,000 active ecological engineering projects involving 10% of the Chinese population (Wang *et al.*, 1998). These systems promote the multi-layer utilisation of spatial and energy resources to maximise production capacity. Pilot projects have included:

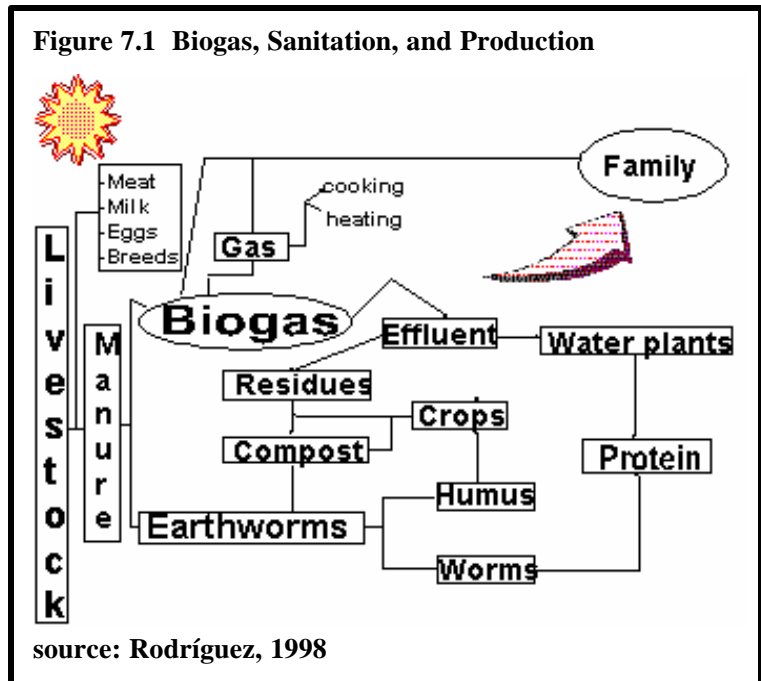

source: Rodríguez, 1998

- ? Ecological engineering for forage-fuel-fertiliser production at the community level;
- ? Fermentation and expansive processing of crop stalks for alternative fodder, paper making or fuels;
- ? Integrative technology for economically affordable sewage treatment and recycling; and,
- ? Systematic technology for domestic garbage sorting, disposal and composting.

Source: Wang *et al.*, 1998

The formal and institutionalised system that has developed in China contrasts with the informal initiative that has transformed wetlands on the eastern edge of Calcutta, India, into a highly productive wastewater treatment and food production system. The Calcutta wetlands are more than 3,000 ha in size, and are the site of the world's largest traditional system for treating domestic wastewater and fertilising fish production ponds (Ghosh, 1991). Wastewater is purified through a variety of natural forces (chemical, physical and solar) which act synergistically to achieve wastewater treatment. A series of shallow ponds act as stabilisation lagoons, while water hyacinth act to accumulate heavy metals, and multiple forms of bacteria, plankton and algae act to further purify the water (Furedy and Ghosh, 1984). Fish production is followed downstream by integrating downstream use of the treated effluent in agriculture and forestry (Ghosh, 1991).

Ghosh (1991) postulates that the wetland treatment technology for wastewater treatment in developing countries offers a comparative advantage over conventional, mechanised treatment systems because the level of self-sufficiency, ecological balance and economic viability is far greater. Furthermore, he states that these systems enable total resource recovery and herald a new era in self-help sanitation for municipalities of developing countries. In a wider and longer-term vision, ecological engineering can offer the opportunity for integrated urban sanitation schemes where wastewater treatment, resource recovery and improved socioeconomic status of the urban poor can become a reality in the developing world. Ghosh (1991:78) has stated, in relation to integrating wastewater resources for urban sanitation, that:

“Our vision, however, extends much beyond designing only a pond system. The actual task is understood as a unified regional development plan to set “waste recycling districts” on the city’s edge. Waste recycling districts will be a new kind of urban facility that will provide food, sanitation, and jobs for the largely impoverished rural folk of the fringe of rural area villages.”

7.2 Advanced Solar Technology

Most recently, the term ecological engineering has been used to describe the treatment of wastewater in ecologically-based "green machines" or "living machines" (Guterstam and Todd, 1990; Mitsch, 1991). The development of solar technologies and an increased understanding of the role of organisms in the water purification process is providing both economic and environmental benefits (Todd and Todd, 1994). Capturing the same natural forces occurring in natural wetland treatment systems, these facilities treat wastewater in confined space environments and are; therefore, suitable for densely populated urban areas.

In these systems, enclosed greenhouses enhance the growth of algae, plants and bacteria which, in turn, act to degrade the biological and pathogenic components of the wastewater effluent. Wastewater effluent flows through a series of clear-sided tanks, engineered streams, and constructed marshes where contaminants are metabolised or bound up (Eco-Tek, 1998). Recovered wastewater effluent from these systems can be used for landscape irrigation, and for the propagation of horticultural plants for resale (Farrell, 1996, WEF, 1995). Whether these systems can become affordable in a developing world context, and specifically in urban regions, is not apparent at this time. However, implementing these facilities in tropical climates would eliminate the need for permanent enclosed greenhouse superstructure. In tropical climates, less expensive enclosures (*e.g.*, tents, or roll-away translucent tarp systems) may be adequate to account for seasonally low-temperature variations. This would result in lower capital construction costs and would potentially enable the implementation of larger systems, designed to serve more users.

Solar Aquatics is ideal for distributed treatment in urban environments (multiple smaller plants versus one large end of pipe solution). *Environmental Design and Management* (EDM) Limited is a Canadian design company specializing in the development of alternative environmental solutions. EDM designed and built the first two Solar Aquatics facilities in Canada, and is currently designing a system for Quyon, Quebec and Meze, France. The Bear River, N.S., Canada facility was the first municipal system in the world, and has won four national and international awards. The system treats to a very high level of water quality with virtually no odour. With few mechanical systems and no required chemicals, the system requires minimal "first world" inputs (*e.g.*, chemicals, power, etc.). This is especially true in warm climates where heating requirements are negligible. For example in the dry arid climate of La Paz, Mexico, the system processes 180,000 US gallons per day and the tanks sit outside without enclosure and are protected solely by sunscreens. In Meze, France (under construction) the enclosed greenhouse will require only minimal external energy to heat the system (R. Cantwell, 1998: personal communication).

Solar Aquatics has numerous advantages for developing countries. Multiple connected treatment systems in an urban environment offer redundancy so that a problem in one area doesn't take the whole sewage treatment system off line. This is especially critical if the water recycling time is short. The primary maintenance (input) to the system is unskilled labour to harvest and maintain the profuse growth of plant material; an easy requirement in most developing countries. Current Solar Aquatics applications in Europe and North America have not tested the potential for food production; however, the system is a nutrient rich hydroponic environment that produces rapid growth of biomass. The un-demonstrated potential for food production necessitates further research in association with Solar Aquatic treatment systems.

Part II: SELECTED TREATMENT TECHNOLOGIES

8.0 LAND-BASED TREATMENT TECHNOLOGIES

Wastewater reuse has been growing over the previous three decades and is now considered an essential management strategy in areas of the world where water is in short supply (Mara and Cairncross, 1989, Khouri et al, 1994). Many countries now consider wastewater reuse as a method to secure water resources (Shelef and Azov, 1996). The benefits of reclaimed wastewater for irrigation, are several, including:

- ? increasing crop yields;
- ? decreasing the use of fertilisers while providing increases in nutrients and organic matter for soil conditioning;
- ? soil conservation and potential reduction of desertification;
- ? improving of the environment by enabling zero-discharge to receiving bodies; and,
- ? enabling the reallocation of freshwater supplies for urban use.

source: (Mara and Cairncross, 1989; Asano and Levine, 1996; Khouri *et al.* 1994).

Box 8.1 Reclaiming Wastewater for Agriculture

“Reclaiming wastewater for agricultural reuse is increasingly recognised as an essential strategy in areas of the world where water is in short supply. Wastewater reuse has two major objectives: it improves the environment because it reduces the amount of waste (treated or untreated) discharged into water courses, and it conserves water resources by lowering the demand for freshwater abstraction. In the process, reuse has the potential to reduce the cost of both wastewater disposal and the provision of irrigation water, mainly around towns with sewers.”

Source: Khouri *et al.* (1994): xi

8.1 Dry vs. Wet Sanitation System

As a shortage of water becomes a reality in many parts of the world, the disadvantages of large-scale water-based conveyance or sewerage systems leads to a consumption of a valuable water resources. This section will discuss alternative options to the conventional water-borne conveyance or wet-sanitation systems that, unfortunately, are aspired to by many countries of the developing world.

Urban areas can consume up to 50% of the total water demand strictly for hygiene related human activities and toilet flushing (Rogers, 1998). A re-thinking of the water-borne approach to human waste conveyance is occurring especially in arid climates where water resources are at a premium. Certainly, in areas such as the Middle East, a rational alternative would be to phase-out the water-borne sewerage systems in exchange for dry-sanitation systems. The concept of dry sanitation in the Middle East is in no way new (see box 8.2) (Winblad and Kilama, 1995). In suburbs and new developments, intermediate-scale collection and treatment schemes should be promoted.

Box 8.2 Composting Toilets in Yemen

“In arid regions it is not very wise to use treated drinking water for toilet flushing. Dry sanitation, i.e., composting or separation toilets, constitutes a viable alternative that should be further developed, adjusted to local traditions and modern health standards, and implemented in many cities. It has to be noted that dry sanitation for disposal and reuse of human manure is an ancient system, known and used for centuries in many dry countries of Africa and Asia. For example, in Yemenite towns dry toilets separating urine and faeces have been used for centuries even in multi-story houses. The traditional system of excreta disposal in the town of Ourgala in the Algerian desert consists of composting latrines. Still, such systems were abandoned in the name of “progress” and water closets substituted, even in dry countries. Thus ancient, and according their standards, well-functioning resource recycling systems developed in agreement with the environment using the experience of generations, became old-fashioned and were replaced by systems that are called “modern” but in reality constitute a step backward in a deep ecological context.

Ancient solutions from Yemenite towns and Algerian deserts cannot, of course, be considered as adequate from a hygienic point of view. But these examples show that several countries have an old tradition of waterless sanitation, suggesting that modern dry sanitation could be incorporated in present sanitation systems without major sociological obstacles.”

Edwards (1985) differentiates between various sanitation options by the amount of water used and this leads to a major distinction between “dry” and “wet” sanitation systems. When human waste is disposed of in buckets, pits, or vaults, it is referred to as nightsoil and must be removed and treated away from the site of collection (Obeng and Wright, 1987). Collection can occur daily or frequently as in the case of bucket latrines or periodically as in the case of a septic tank where a larger capacity exists. In the dry sanitation system, the degree of waste treatment increases with detention time, but must eventually be carted away. It can then be used in agricultural production (Edwards, 1985). Conventional sewerage results in the excreta being removed off-site immediately through a sewerage system, compared to dry sanitation systems that store the excreta on-site.

Asano and Levine (1996) have stated that as wastewater reuse is better defined and understood, shorter recycling loops are possible. There is no shorter closed-loop system than on-site or community level reuse of domestic wastewater. New approaches and novel technologies must be identified that are environmentally-sound for wastewater treatment and recycling must be developed and implemented (Niemczynowicz, 1993; 1996). Many would agree that these solutions already exist and that it is simply necessary to disseminate the technology and for it to gain credibility through demonstration in the developed or newly industrialised countries (Parr, 1996; Niemczynowicz, 1993).

8.2 Land-Based, On-Site Treatment Systems

8.2.1 Double Vault Batch Composting Systems

Several variations of composting toilets, and innovative options will be discussed here. Composting toilets cost as little as one-seventh the cost of implementing a sewerage system in the developing world (Gardner, 1998). Two main types of composting toilets exist, they are *continuous* and *batch*. Continuous composting toilets must be

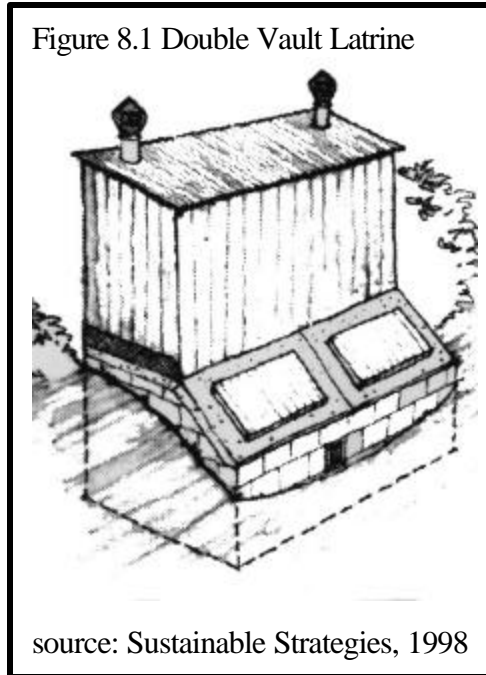

removed from service once the unit is full so that the fresh excreta can be degraded biologically in order to promote maximum pathogen reduction - which usually takes up to one year. Double Vault Batch composting systems, which are commonly used, facilitate the reuse of excreta more easily than continuous systems. They have two adjacent vaults that are used alternately. As the first vault becomes full, the second vault is put into operation. Each vault in the system should be designed large enough to store excreta for 1 year. This will provide adequate time for biological decomposition of the waste and also provides for adequate pathogen reduction.

Double Vault Batch composting systems, though commonly used, are not generally feasible in dense urban areas unless the system is sealed (*i.e.*, blind and impermeable) so that local groundwater resources are protected. The superstructure can be built from locally derived materials and should follow design guidelines that include ventilation to decrease odours and low light conditions which allow insects to be attracted to and trapped in the ventilation chamber. These systems should also be designed large enough to store excreta for 1 year. This management practice will afford safe handling of the resulting humus and ease of application for use in agriculture. Triple vault systems provide even more assurance of pathogen kill because the duration of microbiological activity is lengthened to a three year cycle (Simbeye, 1980).

8.2.2 Composting Toilets and Reed bed Filters

Sustainable Strategies (1998) (see Annex IV: Report Contacts) has had considerable success in implementing composting toilet systems combined with *Water Gardens?* with minimal capital start-up costs. The *Wastewater Garden™* is the result of decades of research by the University of Toronto (Sustainable Strategies, 1998). *Wastewater gardens?*, hereafter referred to as reed bed filters, treat the urine component from the toilet. The reed bed filter assimilates and evapo-transpires the liquid leachate (mainly urine) that is drained from the toilet through a small tube to the exterior of the residence or latrine housing and into the reed bed. The filter is capable of assimilating any greywater that may be generated as well (D. Del Porto, 1998: personal communication). Wastewater effluent percolates or flows through the subsurface root system². In the root system, impurities are removed by combining microbial, chemical and physical processes (Price and Probert, 1997). The composting toilet and reed bed filter combination could potentially be implemented in densely populated urban areas if the

² See Constructed Wetlands, section 13.0 for a detailed description of reed bed filters.

compost toilet - reed bed filter combination technology can be further developed and demonstration projects implemented. Leeflang (1996) has stated that only 1 m² of surface area is required per toilet user and that research continues in the development of substrate bedding materials that are lightweight and can be used on urban balconies and roof-tops. This alternative certainly warrants further research.

Ecological latrine systems, combining composting toilets and reed bed filters, have been implemented in the South Pacific island states of Fiji, Palau, Yap and Kosrae (Sustainable Strategies, 1998). The composting toilet that was used is the Soltran II Non-Polluting Toilet with Carousal Compost System (see figure 8.2) which is also combined with a Wastewater Garden? . The Soltran II is a rather expensive unit for a low-income context. Locally built

units constructed from 45 gallon drums that have been cut in half and adapted accordingly would be much more affordable if local fabrication capacity could be developed.

Sustainable Strategies has also built innovative low cost composting systems for Fiji, Yap, Kosrae, and Pohnpei. A concrete 2-vault block composting reactor latrine system using a fishing net basket for excrement collection costs less than \$500, and even less if recycled materials are used (see figure 8.3). The system appears to have the capability of managing the waste of about 20-40 people per day on a 6-year cycle (three years to fill the first chamber and then three for the second so that removal of the first chamber is after 6 years). Using the net to catch and suspend the faeces, separates solids and leachate, and optimises aeration, and allows composting to occur (D. Del Porto, 1998 Personal communication).

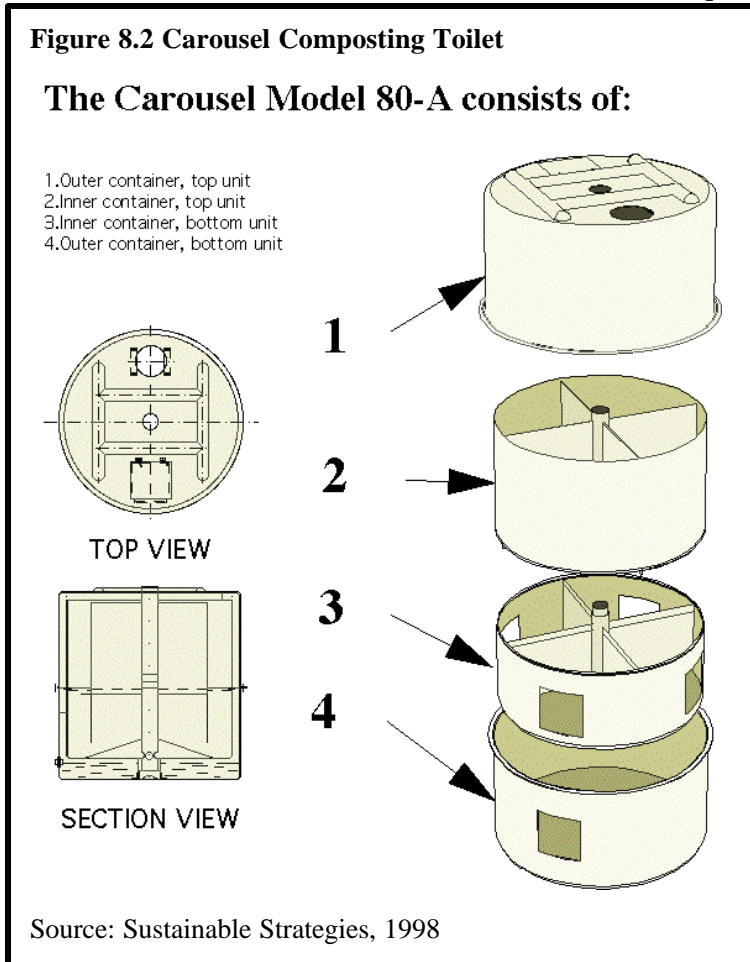

In Fiji, Sustainable Strategies designed a latrine system using nets (as above) in recycled 55-gallon polyethylene drums with quick disconnects to a pint flush toilet. Settled leachate is combined with filtered greywater and applied subsurface into an aerobic evapo-transpiration bed planted with indigenous reeds. The total cost for a 7.5 cubic foot composting system is approximately \$US 40 (Recycled drums - \$6-10/each, fixtures and net - \$US 30). Capacity and filling time is determined by variables affecting composting plus load factors (D. Del Porto, 1998, personal communication). Complete plans, specifications and operation manual for the Drum/Net composter with greywater treatment (*i.e.*, Fiji project - above) can be purchased through Sustainable Strategies' non profit Center for Ecological Pollution Prevention (see Annex IV: Report Contacts).

Recently, the United States Department of Agriculture contracted Sustainable Strategies to design and demonstrate a small-scale piggery waste pollution prevention system in Micronesia in the Federated state of Pohnpei. The system will utilise a Wastewater Garden? to convert pig waste (manure, urine and spilled feed) back into valuable feed plants such as kangkon and water hyacinth. Furniture grade bamboo will also be irrigated and grown from the reclaimed wastewater, and will be harvested and sold (Sustainable Strategies, 1998).

Figure 8.3 Fish Net Basket Collection Latrine with Attached Reed Bed filter or Water Garden?

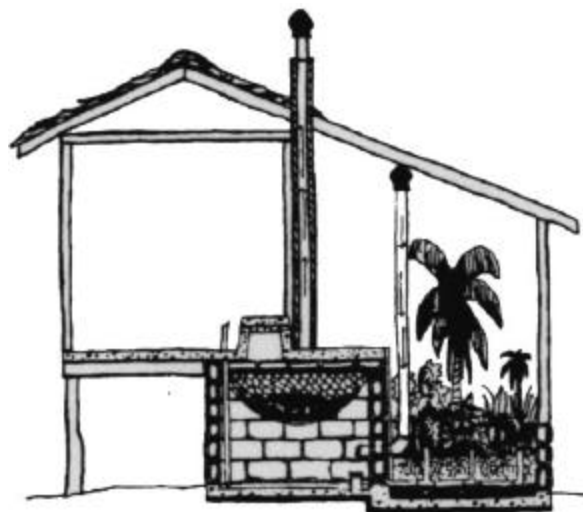

source: Sustainable Strategies, 1998

Composting toilets have been in use in northern communities since the 1970's. One case study in Sweden demonstrated the problems of integrating three different types of dry composting systems into domestic households (Fittschen and Niemczynowicz, 1997). Their study suggested that aspects of planning, maintenance and training need considerable research if these systems are to be integrated into cold climates. In southern tropical climates, composting toilets or dry sanitation systems may be more feasible and efficient at the site-specific level as they can be combined with *reed bed filters* (see box 8.3). Combined composting toilets and filter systems may be appropriate for many Middle Eastern countries where sanitary ablution is practised. The filter is capable of treating and assimilating the additional water while the faecal waste is retained in the composting toilet, where it degrades biologically. The reed bed filters have demonstrated consistent effluent quality in terms of BOD, total suspended solids (TSS) and ammonia-N removal (Green and Upton, 1994 in Yu *et al.*, 1997).

Box 8.3 Helophyte Filters

“The cheapest plant bed filter is a hole in the ground, covered inside with a sheet of plastic, installed with a drainpipe in a bed of crunched shells or pieces of limestone and filled up with very fine sand and eventually with a small or even large content of iron (which helps to eliminate phosphates through binding). In this sandbody we plant reed plants (hollow roots bring oxygen into the filter bed) or other marsh plants, like bamboo, and papyrus depending on the climate and zone. On top we lay the pipe to distribute the wastewater. This kind of plant bed filter gives a very good result and generally speaking 92-97% of most of the organic and inorganic pollution is eliminated. The plant bed filter is self-re-generating: each new growing season the roots get new offshoots, making many new holes in the top layer of sand for the wastewater to penetrate without a chance of clogging which will always happen in a sand filter without plants.”

(Leeflang, 1996): 57

8.2.3 DAFF Latrines

The Dry Alkaline Family Fertiliser (DAFF) latrine is a variation of the Vietnamese latrine and was introduced by the Centro Mesoamericano de Estudios sobre Tecnologia Apropiado (CEMAT) in Guatemala. The DAFF latrine has two alternating chambers where excreta are deposited separate from urine. To ensure biological degradation of the faecal waste, soil or lime can be added instead of or in addition to ash in order to keep an optimal moisture content of the system at around 50% (Mara and Cairncross, 1989). The urine component is conducted to a container and stored for future application to crops (Chavez, 1987). When the first composting chamber is filled, the other has previously been emptied and is then put into use. The main advantages associated with the DAFF are that it produces fertiliser, no sub-surface digging is needed, it consumes little space, it is comfortable, and it can be constructed with local materials (Caceres, 1988).

DAFF latrines produce a compost comprised of 3-10% organic matter, 0.3-1.1% total nitrogen, 150-410 mg/kg. of total phosphorus and 700-7600 mg/kg. of potassium; the pH is 9.8-11.2 (high) due to the supplemented ash. Pathogenic destruction is high enough to use the resulting humus in agriculture. Faecal coliform counts are less than 4000 per gram (wet weight), and helminth eggs less than 8500 per gram with a viability of less than 30% (Zandstra, 1986; Mara and Cairncross, 1989). DAFF latrines cost approximately \$US 140 including construction materials, and the associated educational program that should accompany the implementation of the system. The latrine produces approximately 500 kg. of compost annually that can be sold for \$US 120 (US\$ 1989) (Mara and Cairncross, 1989).

Many composting toilet systems rely solely on desiccation to dehydrate faeces prior to its utilisation in agriculture. Caustic lime or wood ash is often added to the toilet system to reduce odour, but can also act to inhibit aerobic and anaerobic bacterial decomposition processes (Del Porto, 1998). Del Porto (1998) has expressed his concern with the dry toilet systems relying strictly on dehydration as it may result in large masses of re-hydratable faeces, and the associated problems that would develop at the point of the waste reuse. Furthermore, he stated that dried faecal waste requires a biological phase before plants are able to use the nutrients contained in the waste, therefore, he suggests that the design of systems that facilitate biological stabilisation prior to end-use.

8.3 Anaerobic Treatment Systems

When anaerobic bacteria degrade organic materials in the absence of oxygen, methane and carbon dioxide are produced and the methane component can be reused as an alternative energy source. The additional benefits of using anaerobic digestion for wastewater treatment is that a reduction of total bio-solids volume of up to 50-80 percent can be realised and a final waste sludge that is biologically stable is produced that can serve as a rich humus for agriculture (Riggle, 1996). Some technologies are suitable for use at the single household level or can be shared between several households. This section will review those technologies that are feasible for the on-site level. The next section will review those more appropriate at a larger scale, perhaps at a neighbourhood level.

8.3.1 Upflow Anaerobic filters

In 1978 the International Development Research Centre funded the development of an on-site *upflow anaerobic filter* (UAF) treatment system in Thailand. The system is presently being used in Thailand. The system is being used in newly constructed housing units that do not have access to central treatment plants. There are now several companies in Thailand, and in the region that have commercialised this treatment system and now manufacture, and distribute it (Polprasert, 1998: personal communication). The UAF is simple in construction (see *figure 8.4*). It is a rock-filled bed similar in appearance to an aerobic trickling filter; however, the waste is distributed across the UAF bottom and flow is upward through the bed of rocks so that the filter is completely submerged. Results indicate that the UAF is suitable for the treatment of low-strength organic waste and that it

is a viable option because it does not require mechanical equipment; therefore, operation and maintenance of the system was not difficult or expensive.

Figure 8.4 Upflow Anaerobic Filter

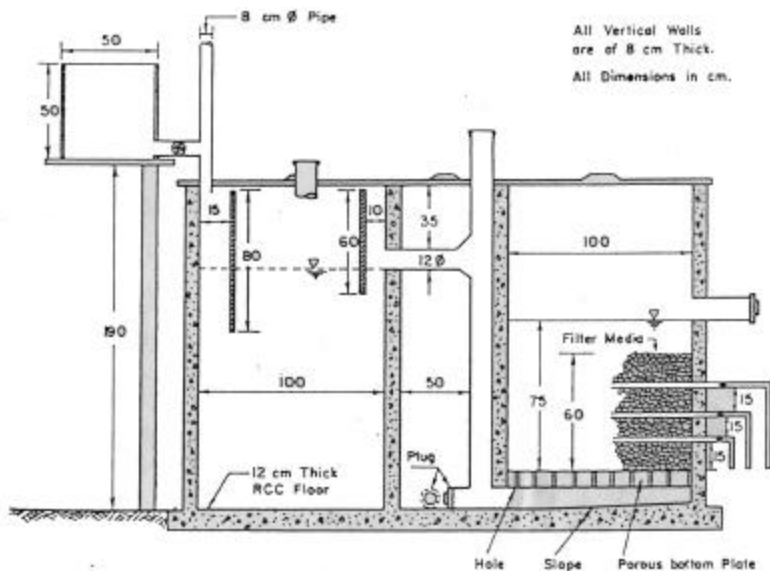

Source: Final Technical Report IDRC Project (78-0097)

Overall, the original research concluded that the UAF was effective in the removal of microorganisms from the wastewater effluent. The removal was especially significant for bacteria. In almost all of the UAF effluent samples analysed, no faecal coliforms were shown when the UAF was operated for a period of four days. It appeared, based on the experimental data, that microbial removal in the UAF occurred primarily through adsorption, filtration, and die-off. The combined septic tank-UAF system proved to be effective in removing microorganisms, particularly helminthic ova and bacteria from wastewater effluent. The helminthic ova that had relatively high specific gravity and large sizes were mostly removed by sedimentation in the septic tank and the remaining helminths further removed in the UAF (Panicker and Krishnamoorthi, 1981). However, because helminthic ova and pathogenic bacteria and viruses can survive in anaerobic conditions, it was suggested that the sludge be handled carefully at the time of filter cleaning, and that the sludge be composted before use as a soil amendment (van Buuren, 1996). Tests determined that the UAF can be used as a viable alternative to conventional septic tank leaching field systems.

More recently, van Burren (1996) reported that a project in Bandung testing the use of on-site anaerobic septic tank system has performed well in serving the needs of 9 persons using 2 pour-flush latrines. Suspended and soluble organic substances were removed to a high extent, and nitrogen (N) and potassium (K) were not removed (favourable for combination with agriculture). The reactor volume was small (0.86 m^3) and BOD and TSS reduction were as high as 80%, and the stability of the sludge was satisfactory.

8.3.2 Biogas Reactors

Biogas technology constitutes a widely disseminated branch of technology with a history of over 30 years (ISAT, 1998). The technology is efficient, well demonstrated and provides a cost-effective method of disposing organic wastes and producing fuel and fertilisers without releasing greenhouse gases (UNDP, 1994). Anaerobic digesters have the ability to destroy pathogenic organisms in wastewater, to produce energy in the form of methane gas, to run water pump engines, electric generators, agricultural machinery, and to produce fertiliser for use in agriculture (Umar, 1996). Integrated systems for the recovery of waste resources and improvements in sanitation should have, at their centre, a biogas reactor (van Buuren, 1996; Doelle, 1998). Biogas is an excellent source of energy and can be used to produce electricity as well as cooking and lighting gas (Doelle, 1998).

A well maintained anaerobic digester should produce $1 \text{ m}^3 \text{ gas} / \text{m}^3 \text{ digester volume}$ and the gas should be constitute 70% methane and 30% carbon dioxide and can be easily reused for cooking and lighting (Hobson and Wheatley, 1993; Doelle, 1998). Gas produced from the system is primarily used for lighting and cooking. Henderson (1998) reports that biogas produced is approximately 60% methane, and that the typical reactor will produce $0.1\text{-}0.2 \text{ m}^3 \text{ biogas} / \text{m}^3 \text{ digester volume} / \text{day}$. More than 60% of the feed-stock to reactors should be water and urine with bio-solid waste comprising the remainder (Hong, 1993). Because of this fact, biogas technology also shows the potential for use in Middle Eastern countries where sanitary ablution is practised. Otterpohl *et al.* (1998) have suggested that communal toilets built directly over a sub-surface biogas system would be feasible. In communal systems, methane could be recovered and lighting could be provided to increase the attractiveness at night and to decrease vandalism of the facility (Marks, 1993). Major advances have been made in Nepal where the installation rate of family size biogas plants in Nepal has shown unprecedented growth in the past and is expected to continue over the next ten years (FAO, 1999).

Digestion usually occurs over a five to six day period for maximum biogas generation (Chan, 1993). Treated slurry is used as a fertiliser, but can also be used as a feed supplement for pigs, mushroom growing media, as a fertiliser for fish ponds, and vermicomposting substrate (Henderson, 1998, Rodríguez *et al.*, 1998). Bo *et al.*, (1993) have noted that the anaerobic digestion of nightsoil waste prior to the fertilisation of fish ponds is widely practised in China.

In addition to the sanitary benefits, the biogas technology can provide stabilised organic inputs for agriculture. Increases in economic yields of 30% have been noted where reactor effluent is used as a substitute for chemical fertiliser (Wu and Lui, 1988). Similar increases in yields have been noted when reactor effluent is used to fertilise mushroom and fish production (Di, 1993). Using biogas as an alternative energy source can also decrease the amount of firewood that is cut and burned for cooking in countries like Africa (Umar, 1996; ISAT, 1998). Biogas also holds the potential to enhance the economic growth in developing countries because of the reduction in the use of fossil fuels (NRC, 1981; UNEP, 1984; Barnard and Kristoferson, 1985; Marchaim, 1992; SPORE, 1995).

In Tanzania there are over 5,000 small-scale plants designed for rural production of cooking or lighting fuel from cow manure. The implementation of biogas technology in Tanzania dates back to 1975 (UNDP, 1994; ISAT, 1998). The UNDP has co-financed the construction of a large-scale biogas plant in Dar es Salaam, Tanzania. The plant will have the capacity to treat 60 tons of organic waste per day, or 3 percent of the waste produced daily in Dar es Salaam. Although this is a centralised, highly capitalised technology, the project will act as a model demonstration to promote the technology and it is expected to reduce Tanzania's dependence on fossil fuel imports and to increase the availability of fertiliser (UNDP, 1994).

Box 8.4 Biogas Reactors and Sanitation

“The processing of animal and human excrement in biogas systems obviously improves sanitary conditions for the plant owners, their families and the entire village community. The initial pathogenic capacity of the starting materials is greatly reduced by the fermentation process. Each new biogas system eliminates the need for one or more waste/manure/latrine pits, thereby substantially improving the hygiene conditions in the village concerned. From a medical point of view, the hygienic elimination of human excrement through the construction of latrines, connected directly to the biogas systems constitutes an important additional asset. In addition, noxious odors are avoided, because the decomposed slurry stored in such pits is odorless” (ISAT, 1998).

source: ISAT, 1998:

http://gate.gtz.de/isat/at_info/biogas/AT_biogas.html

The Zambian National Council for Scientific Research has set up several biogas demonstration projects around the country to popularise the technology as a source of energy (Kayaya, 1997). Kayaya has also reported that Zambian researchers consider biogas technology of central importance in the improvement of sanitation, the provision of energy and in the reduction of deforestation. Umar (1996) reports that the implementation of biogas plants would be feasible in Nigeria based on the availability and accessibility of organic waste materials, and the technical resources that are available in local universities. He also states that average year-round temperatures would make the technology feasible and that local construction materials (bricks, valves, tubes hoses and masonry labour) are available in Nigeria.

Biogas technology has faced a series of problems in numerous areas where the technology has been introduced. These problems have been the result of technical failures, poor selection of reactor type, institutional complexities, and lack of sociocultural acceptance. In Tunisia, even after the implementation and success of 18 pilot plants in Sejenane (1986 - 1987) and El Kef (1991 - 1992) had been demonstrated, the German Technical Agency for Technical Cooperation (GTZ) *Special Energy Programme - Tunisia* came to a standstill, not because of technology failure, but because of a multi-level socioeconomic complex of problems (ISAT, 1998). The GTZ (ISAT, 1998) reports that in Morocco, according to records held by CDER (Centre de Développement des Energies Renouvelables), in 1992 there were 255 biogas plants in Morocco mostly with digester volumes of 10 m³. However, reports by CDER show that a large percentage of the biogas plants are not functional at this time and that a systematic analysis of the causes taking a differentiation between technical reliability and problems originating in social acceptance into consideration is not yet available (ISAT, 1998). It is imperative that sociocultural, political, economic and ecological conditions must be well understood before a technology is implemented.

8.3.3 Recent developments in biogas technology

Considerable efficiency and low implementation costs have been associated with recent use of Tubular Polyethylene Digesters (TPED) a variation of the standard biogas reactors. In Vietnam and the Philippines, plastic bio-digesters are being used in combination with confined space animal production. In the Philippines, the Bureau of Animal Industry is implementing a program using the TPED to abate environmental risk posed by widespread backyard livestock production. Ninety-nine units have been installed nation-wide at this time, of which, 8 are used for demonstration purposes (Moog, *et al.*, 1997). This technology was based on the model developed in Colombia (Botero and Preston, 1986) and modified by experiences in Vietnam (Bui Xuan An *et al.*, 1995; Bui Xuan An *et al.*, 1997; Moog *et al.*, 1997). As of September 1998, more than 7,000 TPED have been installed in Vietnam, mainly paid for by farmers (Rodríguez *et al.*, 1998).

Box 8.5 Plastic Tubular Polyethylene Digester

“The low-cost plastic biodigester can be used in different scales according to the farm situation. For the small-scale farmer in remote areas where fuel is not easily available the biogas plays an important role as a source of fuel especially for cooking. In other areas, where fuel is available, the potential of the digester is the use of the effluent for fertilization of crops...”

Source: Rodríguez *et al.*, 1998: 11

In China, the Chinese fixed-dome reactor has been widely used. Reports of built biogas digesters range from five to seven million (Nazir, 1991; Henderson, 1998). The cost in China to build a family size reactor from locally derived materials is approximately \$US 80 (Henderson, 1988). The government has actively promoted the technology since the 1970s - mainly in rural areas. ISAT (1998) reports that in 1992 there were 1.7 million plants in operation in the Szechuan province. It is common that the latrine and livestock waste collection system gravity feeds into the biogas reactor, thus reducing labour and human contact with the waste and labour. Often, the reactor is located directly under the flooring of livestock enclosures and pigsties, where animal wastes can easily be washed, swept or drained into the reactor (Chen, 1997). Increases in general sanitation have occurred where biogas reactors are used, and has resulted in hygienic and convenient toilet systems being implemented very close to living quarters. In the past, latrines have been located at a distance from houses due to their odour and the presence of insects (Henderson, 1998).

They have been used extensively for integrated farming system in rural environments. Biogas systems have several benefits including sanitation and the production of fertiliser as a production input for agriculture. Considerably more research is required; however, to determine methods and approaches to successfully integrate these systems into urban environments.

Box 8.6 Benefits of Biogas Technology

- 1) transformation of organic waste into high quality fertilizer;
- 2) improvement of hygienic conditions through reduction of pathogens, worm eggs and flies;
- 3) reduction of workload, mainly for women, in firewood collection and cooking;
- 4) environmental advantages through protection of soil, water, air and woody vegetation;
- 5) micro-economical benefits through energy and fertilizer substitution, additional income sources; and,
- 6) increasing yields of animal husbandry and agriculture; macro-economical benefits through decentralised energy generation, import substitution and environmental protection.

Source: ISAT, 1998:

http://gate.gtz.de/isat/at_info/biogas/AT_biogas.html

8.4 Off-Site Anaerobic Treatment Systems

8.4.1 Upflow Anaerobic Sludge Blankets

Anaerobic treatment technologies, as noted by McCarty (1981, 1985) were explored as early as 1881 (Garuti, *et al.*, 1992). However, low-cost anaerobic treatment technologies such as the mechanised anaerobic upflow sludge blanket (UASB) have shown considerable promise only recently (Switsenbaum and Jewell, 1980; Lettinga *et al.*, 1981). Since the early 1980s, considerable research and development has occurred in relation to anaerobic wastewater treatment systems and specifically, UASBs (Yu, *et al.*, 1997). Reductions in BOD of 75% - 90% have been noted in tropical conditions (Schellinkhout, and Collazos, 1992; van Buuren, 1996). The UASB technology is feasible in an urban, developing world context because of its high organic removal efficiency, simplicity, low-cost, low capital and maintenance costs and low land requirements (Lettinga and Hulsffof, 1991; Garuti, *et al.*, 1992; Yu *et al.*, 1997). Anaerobic treatment processes are suitable in tropical conditions because anaerobic treatment functions well in temperatures exceeding 20°C (Yu, *et al.*, 1997). They are characterised by low sludge production and low energy needs (Garuti, *et al.*, 1992).

The Upflow Anaerobic Sludge Blanket (UASB) is typically constructed with entrance pipes delivering influent to the bottom of the unit and a gas solids separator at the top of the reactor to separate the biogas from the liquid phase (water and sludge), and of sludge from the water phase - to prevent sludge wash-out (see *figure 9.5*) (van Buuren, 1996). Anaerobic treatment technology offers the opportunity to treat wastewater, convert the organic matter to natural gas and recover the nutrient rich treated effluent for irrigation (Jewell, 1996).

In a first phase demonstration project in Bucaramanga, Colombia, a combined sewer systems and UASB treatment facility resulted in the city becoming more advanced in sanitation than any other Colombian city (Schellinkhout, and Collazos, 1992). The system was implemented at a cost of \$US 17 per capita (including 30 km. of extended sewers), served 160,000 *population equivalents* (PE), and operated at \$ US 1.50 per annum per capita for personnel (Schellinkhout and Collazos, 1992). When land cost are less than US\$ 20, a temperature of

25° C and a system scale of 50,000 PE can be attained, the UASB with WSP post treatment systems can cost US \$4/PE compared to activated sludge systems at US \$8/PE (Oomen and Schellinkhout, 1993, in van Buuren, 1996).

Figure 8.5 Typical UASB Construction

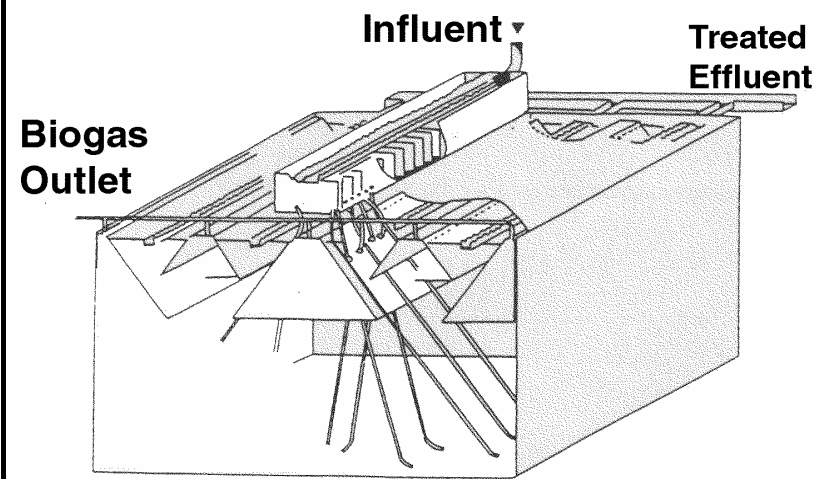

Source: Jewell, 1996

In the treatment of wastewater resources it is important that the nutrient resources (nitrogen and phosphorous) be conserved (as opposed to stripped) if the wastewater is destined for use in agricultural irrigation, and that the technology should be chosen appropriately (Jimenez- Cisneros and Chavez-Meija, 1997; Denny, 1997). Because nitrogen and phosphorous are not effectively reduced in anaerobic technologies, this primary treatment approach is complementary when used in parallel with agriculture or aquaculture.

Anaerobic treatment processes are not considered effective in the destruction of pathogens and must be followed by a post-treatment option to meet increasingly strict discharge standards now seen in the developing world (Garuti, *et al.*, 1992; Yu, *et al.*, 1997). Alaerts *et al.*, (1993) report a 90-99% removal of helminths in wastewater with the UASB technology. Tertiary treatment options may include composting of digested sludge for final pathogen reductions and treatment in WSPs or constructed wetland systems. Literature on secondary and tertiary treatment processes in combinations with the UASB technology is poor at this time (Garuti, *et al.*, 1992).

The ability of small, on-site anaerobic treatment systems, such as those described, suggest that they may be suitable for increased use in the urban environment. These systems are capable of attain high levels of wastewater treatment, produce minimal sludge that is, itself, high in N-P and are capable of producing biogas energy that can be recovered and reused.

8.5 Soil Aquifer Treatment

When aquifers are artificially recharged with partially treated sewage effluent, and then withdrawn for future use, the benefit is "treatment" as opposed to artificial recharge, and the process is referred to as soil-aquifer treatment (SAT) or geopurification systems (Bouwer, 1993b). SAT provides purification during the flow of effluent through the soil of the unsaturated zone and in the aquifer. Effluent percolates through the unsaturated zone until it reaches the aquifer and moves readily to recovery wells (Asano and Levine, 1996).

In southern Israel, between 1991-1996, 400 million cu. m of reclaimed municipal wastewater was supplied for unrestricted irrigation using SAT (Kanarek and Michail, 1996). Cost estimates suggest that the SAT treatment is much less expensive than electro-mechanical treatment systems and that most of the cost will be associated with pumping the water from the recovery wells: approximately US\$ 20 - 50 per 1000 m³ (Bouwer, 1993b). Wastewater used for artificial recharge and treatment schemes is sometimes treated to conventional primary and sometimes secondary levels. However, Bouwer (1993a) has stated that because SAT removes more BOD than is in secondary effluent, secondary treatment is not needed and the higher organic carbon content of primary effluent may enhance nitrogen removal by denitrification in the SAT system (Lance *et al.*, 1980).

These systems are inexpensive, efficient (in terms of pathogen removal) and operation is not considered highly technical (Bouwer, 1993a). In terms of reductions, SAT systems typically removes all BOD, TSS, and pathogenic organisms from the water and tend to treat wastewater to a standard that would generally allow unrestricted irrigation (Bouwer, 1991). Bouwer has noted that one of the major advantages of SAT is that it breaks the pipe-to-pipe connection of directly reusing treated wastewater from a treatment plant, which is of advantage in some cultures where the reuse of wastewater may potentially be taboo.

9.0 WATER-BASED WASTEWATER TREATMENT TECHNOLOGIES

Wastewater projects that rely on natural process (biological, chemical and physical) to drive or power the system can attain high levels of sanitary control for the relatively low initial capital outputs. Several technologies fit this definition. Wastewater stabilisation ponds, constructed wetlands and aquaculture ponds are examples of centralised natural treatment systems. Natural treatment technologies deserve priority consideration over mechanised treatment systems in the developing world because they offer several advantages over conventional systems (Veenstra and Alaerts, 1996; Haberl, Perfler and Mayer 1995). Veenstra and Alaerts (1996) have stated that they can be operated and maintained easily at the local level and do not rely on imported equipment or specialised skilled operators; however, their one limitation is that large land requirements are necessary.

9.1 On-site Wetland Treatment

Siting and constructing sewerage systems are difficult tasks in urban areas because a variety of factors including spatial availability and inclined or rocky marginal land make it difficult. However, the development of some technologies may make the integration of low-cost decentralised systems in marginal areas easier in the future. Reed bed filters and small-scale constructed wetlands, at the household-level, are not well developed and more research is necessary in this area. The following technology was designed for on-site, confined space wastewater treatment. It uses aquatic plants and the upflow filter concept to treat wastewater.

The system (*figure 9.1*) is unique in that it combines wastewater treatment and resource recovery in a relatively small system that may be suitable for use in urban areas and has been described for use in moderate land limited conditions for schools and hotels where sewer lines are not available (Yang *et al.*, 1994). Chen (1992) states that the system's spatial requirements are lower than conventional aquatic plant treatment processes and facultative pond systems.

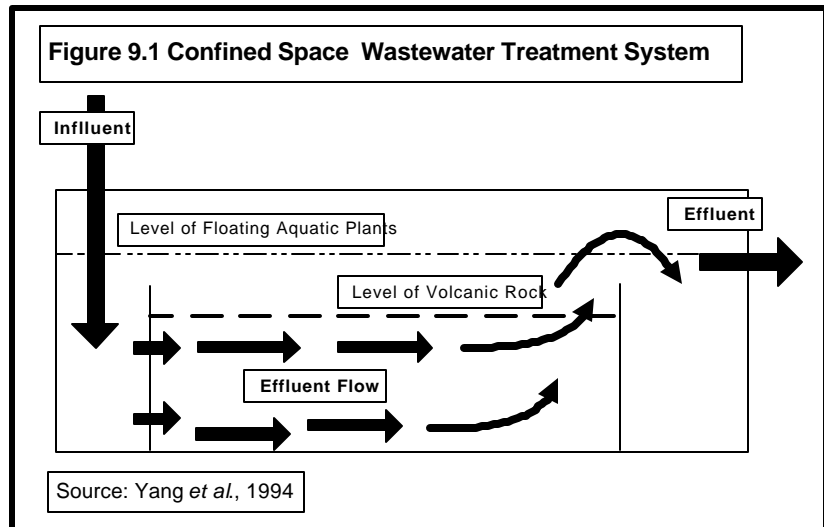

The free-floating aquatic macrophyte and sub-surface bio-fixed film treatment system demonstrates high BOD⁵ and nitrogen removal efficiencies of more than 85% at a loading rate of 135 kg/ha/day (Yang *et al.*, 1994). Two systems have been investigated at this time: a horizontal flow fixed film system using volcanic stone and aquatic plants (*figure 10.1*) and a vertical flow fixed film system.

Box 9.1 Horizontal Combined Bio-Fixed Film With Aquatic Plants

"In the horizontal flow single pond system, two wooden reactors were constructed in a size of 1.2 m. x 1.0 m. x 0.5 m. (Length x Width x Height) each ... The total volume of the reactor was about 400 L. The volcanic rocks were filled to a depth of 35 cm. The void volume of 220 L. and the packing ratio to the total volume was about 0.45. The direction of wastewater flow was horizontal through rock medium and upflow towards the liquid portion and the aquatic plants, and then discharged through the other end of the tank."

Source: Yang *et al.*, 1994: 2

9.2 Off-Site Constructed Wetlands

Wetlands constructed specifically for treating wastewater are known as "constructed wetlands" and are effective in the removal of BOD, TSS, and nitrogen (N) (Tchobanoglous, 1991; Brix, 1994). The beneficial uses of these systems for wastewater treatment are well established, and the technology continues to develop rapidly (Tchobanoglous, 1991; Price and Probert, 1997). Some of the earliest studies using forested wetlands to treat domestic wastewater demonstrated that nutrients could be removed with a minimum application of expensive and fossil energy consuming technology (Mitsch, 1977; Mitsch, 1991). Constructed wetlands have also been used in the renovation of coal mine drainage (Mitsch, 1991). Constructed wetlands are widely used in the United States, the U.K. and northern Europe.

9.2.1 Subsurface Wetlands

Subsurface wetlands are lined ditches that have been filled with a gravel, sand or soil substrate and planted with appropriate plant varieties such as reed or helophytes (see *figure 9.2*). Treatment in subsurface systems generally occurs when the effluent makes contact with plant roots and the soil or rock bed (Price and Probert, 1997). Influent enters the treatment system and percolates through the substrate. Organic matter is biodegraded either aerobically or anaerobically, nutrients are eliminated through a variety of biological, physical and chemical processes and a certain degree of water is transpired (Brix and Schierup, 1989; Haberl *et al.*, 1995; Mandi,

Figure 9.2 Reed Bed Wastewater Treatment Design

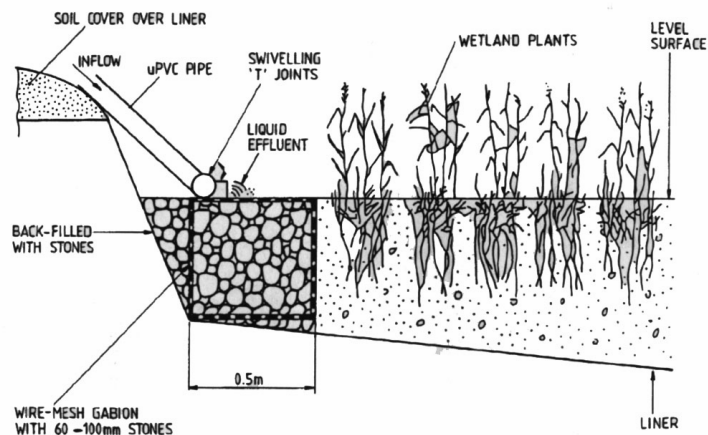

source: Price and Probert, 1997

1994). One of the major advantages of reed bed treatment systems is the low maintenance requirements (Green and Upton, 1995; Price and Probert, 1997). Reed bed systems do not require imported parts. If local clay for lining, and local stone for a root-zone substrate are available, construction costs can be very low (Green and Upton, 1995). Reed bed systems have demonstrated considerable efficiency when combined with an advanced, but low-cost composting toilet design (see section 8.2).

9.2.2 Free Water Surface Wetlands

This following section will focus strictly on *free-floating aquatic macrophyte* wetland systems and the resources recovery options that exist when floating aquatic macrophytes are considered in wastewater treatment. The discussion will focus on free-floating wetland systems, and will encompass both water hyacinth and duckweed.

Free water surface (FWS) wetlands are typically shallow channels or basins where the water surface is open to the atmosphere and a suitable medium exists to support the growth of emergent or submerged aquatic plants (Middlebrooks, 1995; Tchobanoglous, 1991). FWS wetlands support the growth of floating aquatic plants, as well as, emergent and submerged varieties. Wastewater treatment occurs as the plants assimilate nutrients (nitrogen and phosphorous) from the effluent and the resulting biomass is harvested (Brix and Schierup, 1989). Two floating aquatic macrophyte plants have been most commonly used in wastewater treatments systems at this time, they are: water hyacinth (*Eichhornia crassipes*) and duckweed (*Lemnaceae sp.*, *spirodella sp.*) (Middlebrooks, 1995). Macrophyte-based wastewater treatment systems are appropriate because they offer several advantages over mechanised treatment systems: 1) they have low operating costs; 2) they operate with low energy requirements; 3) they can often be established at the site of wastewater production; and, 4) they are more flexible and more tolerant of shock loading (Brix and Schierup, 1989).

The value of constructed wetlands continues to be demonstrated. Brix (1994) states that present state of knowledge is adequate to apply constructed wetlands as a tool for secondary and tertiary wastewater treatment and, that in many cases, constructed wetlands are the only appropriate technology. Denny (1997) has stated that the use of constructed wetlands in the developing world must be considered, both because of their ability to improve water quality, but also to provide a sound foundation for conserving natural wetland sites.

9.3 Floating Aquatic Macrophytes

Several varieties of macrophytes show considerable promise for the treatment of wastewater and have been employed for this purpose in a number of tropical and sub-tropical countries (Brix and Schierup, 1989). Numerous studies demonstrate the value of floating and emergent aquatic macrophytes to perform wastewater treatment (Brix and Schierup, 1989; Tchobanoglous, 1991; Zhenbim *et al.*, 1993). Water hyacinth and duckweed, water lettuce (*pistia stratiotes*) and salvinia (*salvinia spp.*) have shown high performance potential as well (Brix and Schierup, 1989). Duckweed and water hyacinth both function in the removal of nutrients, the suppression of algae and sequestering trace organics (Middlebrooks, 1995; Mandi, 1994). Additionally, these treatment systems are capable of producing biomass in amounts large enough to make the operation cost effective when the biomass is sold as animal forage or fish feed.

In a demonstration floating aquatic treatment system in Huangzhou City, China, Zhenbim *et al.* (1993) note that macrophyte systems appear to function as fixed film reactors with the root system (rhizosphere) acting as a substrate for bacteria to grow and decrease levels of BOD in the wastewater. Experiments have shown that bacteria and microorganisms are abundant in the subsurface (rhizosphere) of the macrophytes and that reductions occur as the water passes through the rhizosphere complex of the floating macrophytes (Zhenbim *et al.*, 1993). These experiments demonstrated that BOD⁵, COD, TSS, N, P, viruses and bacteria could be greatly reduced and that the resulting water is suitable for use in irrigation and aquaculture.

9.3.1 Water Hyacinth

Water hyacinth grow profusely in many parts of the tropics. Their use as the functional unit in wastewater treatment systems has been increasingly demonstrated and treatment regimens developed as results of successful pilot projects are documented (Brix and Schierup, 1989; Mandi, 1994). Wastewater treatment with water hyacinth has been successfully implemented by the city of San Diego, USA, to produce a treated effluent attaining quality standards that would be expected from advanced secondary treatment processes (Tchobanoglous *et al.*, 1989). Water hyacinth can be used in both tertiary treatment systems, for the removal of nutrients and in integrated secondary and tertiary treatment systems where both BOD and nutrient removal is the goal (Brix and Schierup, 1989; Middlebrooks, 1995).

Water hyacinth have also been demonstrated in the treatment of raw wastewater and have provided 17% lower levels of BOD and TSS when compared to wastewater stabilisation pond effluent (Kumar and Garde, 1989; Mandi, 1994). It is believed that two major mechanisms for ammonia reduction in hyacinth systems are bacterial nitrification and plant uptake (Hauser, 1984). Water hyacinth also produce high yields (approximately 30 g/day/m² dry matter), but their overall value is low because their mass is offset by its low nutrient value, low digestibility, high harvesting expense, and water loss by evaporation. Therefore, they are not an attractive commodity compared with other aquatic macrophytes such as duckweed (Oron, 1990; Alaerts *et al.*, 1996).

In terms of bacterial reduction by water hyacinth-based systems, two theories exist. First, bacteria are trapped in the rhizosphere of the macrophytes with TSS, and second, water hyacinth may secrete chemical substances having bacteriostatic effects (Mandi, 1994). *Ascaris*, *Taenia* and *Trichuris* eggs settle to the sediment rapidly in water hyacinth ponds; therefore, particular attention should be paid to the management of sediment if pathogen control is to be attained (Mandi, 1994). Pathogen reduction levels are not attained in water hyacinth-based systems to the same level as wastewater stabilisation ponds (WSP)(Mandi, 1994).

9.3.2 Duckweed

Duckweed is another aquatic macrophyte that is proving to be very efficient at the centre of a wastewater treatment system. Duckweed has a very high nutritional value of 35-45%, depending on the species, which makes it potentially profitable in for use in secondary processes (Skillicorn *et al.*, 1993). Duckweed value, in terms of protein content, is similar to soybeans at \$US 0.20/kg (1990 figures) (Oron, 1990, 1994). If grown on domestic wastewater free of heavy metals, duckweed can be used as an animal fodder and green fertiliser (Oron, 1990, 1994; Bonomo *et al.*, 1997).

Figure 9.3 Duckweed Harvest



Compared to water hyacinth, duckweed-based wastewater treatment systems play a smaller role in BOD removal, but are efficient in the removal of nutrients and can play a significant role in TSS reductions (Zirschikly and Reed, 1988; Brix and Schierup, 1989; Mandi, 1994; Ngo, 1985). Generally, TSS, BOD and pathogen removal undergo the same process as with WSPs and thus, duckweed-based treatment systems are enhanced lagoon systems (Bonomo *et al.*, 1997). Nutrients (N, P) are generally sequestered in the plant biomass and are removed through harvesting (Bonomo *et al.*, 1997). Algal growth is suppressed by duckweed because of competition for both sunlight and nutrients, but it has also been hypothesised that the rhizosphere complex may also secrete organic substances which suppress and kill algae cells (Zhenbim *et al.*, 1993).

9.3.3 Cropping system management

Cropping system management and stocking density of the floating plants is very important if optimal harvests are to be consistently attained. In water hyacinth-based systems, Tchobanoglous *et al.* (1989) have reported that optimal harvests occur when no gaps exist between plants. Fifty percent of the crop density is removed during harvest, and this process is repeated as the hyacinth grow. In the duckweed-based system, harvest occurs daily to maintain an optimal crop density of 600 g/m² (PRISM-Bangladesh, 1998). Increases in biomass production can be expected with effective crop management and maintenance of optimal crop density in both the water hyacinth and duckweed-based systems (Brix and Schierup, 1989; Zhenbim *et al.*, 1993; Bonomo *et al.*, 1997).

9.3.4 Disease vector management

Water hyacinth are known to promote mosquito breeding. Efficient and systematic management of the cropping system can reduce the number of mosquito larvae. Success in checking larvae populations has been demonstrated when dissolved oxygen levels can be kept at 1.0 mg/L and when frequent harvesting and thinning of the water hyacinth occurs (Tchobanoglous *et al.*, 1989). Mosquitofish (*Gambusia affinis*) have also been effective in mosquito control as clearing the pond of dead plants and decaying plant matter (Hauser, 1984). Chemical agent BTI (*Bacillus thuringiensis israelis*) and Golden Bear Oil 1111 have also been effective and apparently do not decrease effluent quality (Tchobanoglous *et al.*, 1989). Duckweed-based systems work efficiently to actually suppress mosquito populations because duckweed forms a complete mat over the water surface that prevents mosquito larvae populations from reaching the water surface (Bonomo *et al.*, 1997; PRISM-Bangladesh, 1998).

Box 9.2 Duckweed-Based Wastewater Treatment Efficiencies

“High removal rates in terms of concentration, and significant rates in terms of load, were observed during the dry and wet seasons. COD and BOD⁵ concentrations were reduced by 90-97 and 95-99%, respectively, and Kjeldahl-N and total P by 74-77%. NH⁺₄ and O-PO³₄ were nearly completely exhausted. Ninety percent of the nutrient uptake by the duckweed took place in the first three compartments, or within 7.3 d actual retention time. Similarly, the same pertains to BOD₅ load removal; 90-90% removal was obtained at this retention time, equivalent to a loading rate of 80-90 kg BOD₅/m²/day, as compared to 48-60 for the present whole lagoon. This suggests that the lagoon can accommodate higher loadings and its design could be further optimised.”

source: Alaerts *et al.*, 1996: 850

9.4 Duckweed-Based Pisci-culture: PRISM-Bangladesh

PRISM-Bangladesh, a non-government organisation based in Dhaka, Bangladesh, has developed a highly successful Duckweed (*sp. Lemnaceae*) cropping system for both domestic wastewater treatment and the production of fish protein (Skillicorn *et al.*, 1993). PRISM has standardised and optimised the duckweed management and cropping system to treat the wastewater generated at the Kumandini Medical Complex in Mirzapur, Bangladesh. Experimental trials and data collection undertaken between 1989 and 1991 resulted in a strategy to optimise the production of duckweed for the cultivation of carp and tilapia and treat wastewater to a high efficiency.

The spatial requirement for this system is very low: 0.7 ha of surface area on 1.0 ha of total land (not inclusive of a 0.2 ha primary stabilisation lagoon or the total 0.4 ha fish production ponds). Approximately 0.5 million litres of raw sewage are pumped daily from the complex and into the waste treatment system. The present wastewater treatment system in Mirzapur treats the waste stream of 2,500-3,000 people (year average production of approximately 78 l/per capita/day) (Alaerts *et al.*, 1996).

PRISM's wastewater treatment system is composed of a three stages and treatment occurs incrementally:

- (1) **primary treatment phase:** a waste stabilisation pond (0.2 ha) provides a 24-hour detention for settling-out solids;

- (2) **secondary treatment phase:** a plug-flow system (0.7 ha) where chemical pollutants (nitrogen, phosphorous, calcium, sodium, potassium, magnesium, carbon and chloride) are removed by the rapidly growing duckweed plants which act as a nutrient sink in reducing chemical loads and;
- (3) **tertiary treatment:** as wastewater travels through the plug-flow system, nutrient loads become incrementally smaller as duckweed plants begin processing increasing amounts of water in search of nutrients and, in the process, absorb almost all chemical substances in the wastewater.

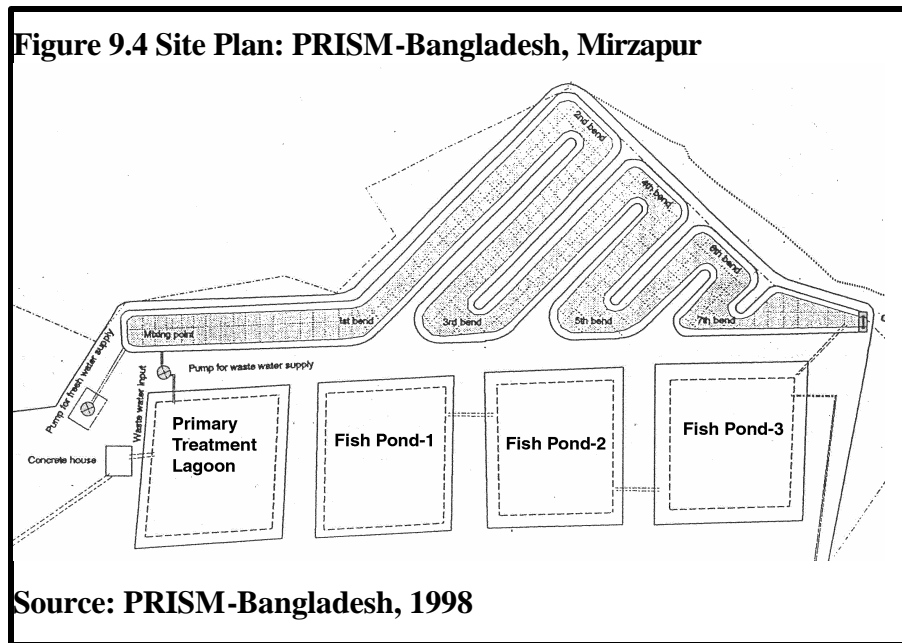

Treated wastewater from the Mirzapur system is directed into three fish production ponds of 0.2 ha each. Pathogen monitoring performed by the International Centre for Diarrheal Disease Research-Bangladesh (ICDDR-B) during a one year period confirmed that no pathogens were transmitted based on a variety of tests, including samples from wastewater, duckweed harvest, effluent from different locations through the plug-flow system, fish gut and scale, sampling of workers by finger and anal swap, and general health observations. These observations confirmed that there was no transmission vector of enteric diseases to workers (PRISM, 1998).

9.5 GreenGold Corporation

The GreenGold Corporation has developed a space efficient duckweed production system as recently as 1996. Influent and effluent enter and exit the system in side-by-side folds of the helix shaped treatment design (see figure 9.5). Harvesting is performed mechanically from a harvesting unit that rotates on a centre pivot and outer wheel.

Box 9.3 The Green Gold Corporation and Duckweed-Based Wastewater Treatment

"The GreenGold Corporation is a developer of integrated systems for aquaculture and wastewater treatment.

The signature process in these systems is the cultivation of Lemnaceae, or duckweed: a family of high-yielding aquatic plants of exceptional nutritional value. The central component in the GreenGold design is a Helical Production Unit (HPU) in which a rapidly growing duckweed mat is maintained on the surface of diluted wastewater as it flows through the channels of the unit.

HPU's are harvested daily to produce a continuous crop of protein-rich duckweed plants for animal feed. GreenGold has designed equipment and processes for ensuring both the safety and the nutritional value of the harvested duckweed. In an integrated system, treated duckweed and water serve as inputs to facilities for feed production, fish aquaculture, and/or vegetable production."

Source: GreenGold Corporation, 1998: <http://www.ntrnet.net/~skilli/NWW.htm>

Figure 9.5 GreenGold Duckweed Production Pond Design

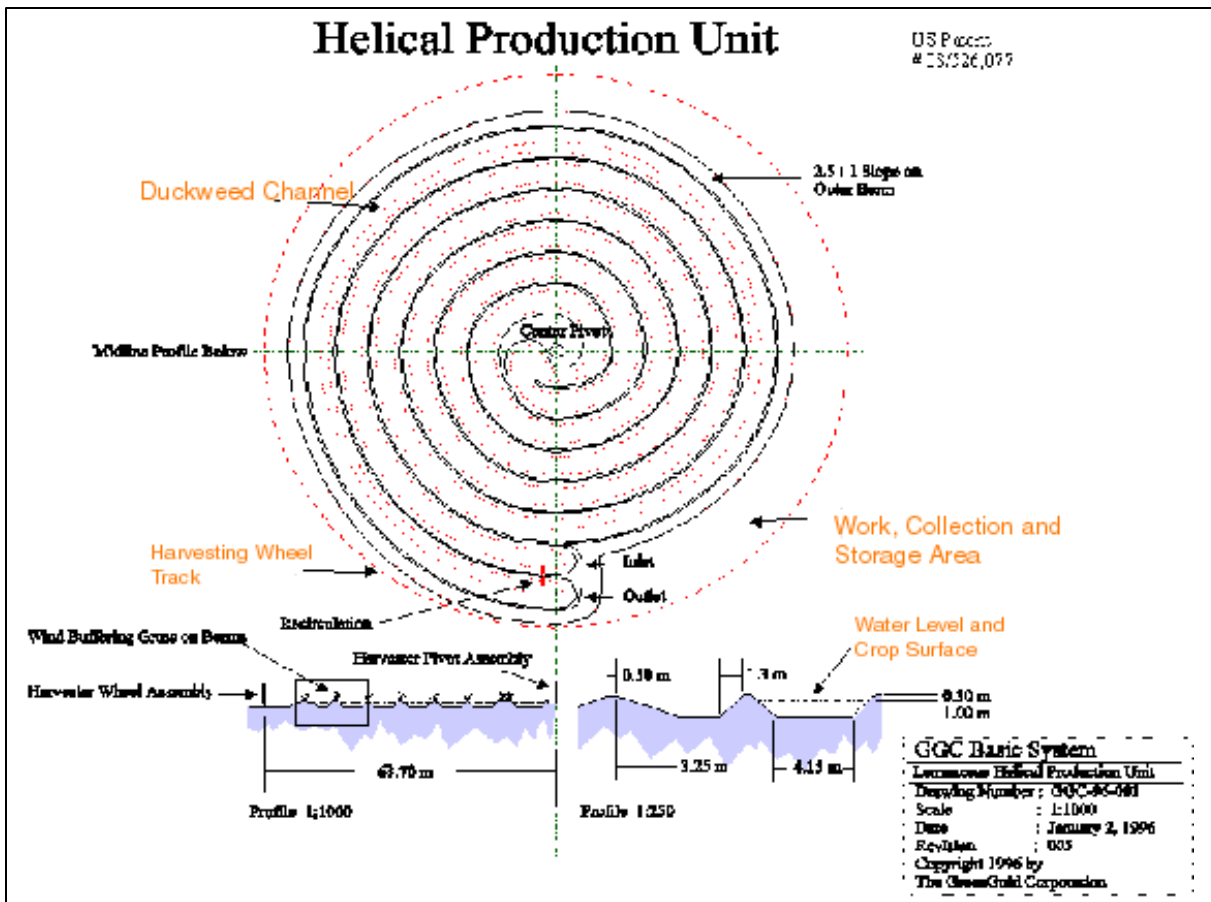

Source: GreenGold Corporation, 1998: <http://www.ntrnet.net/~skilli/NWW.htm>

9.6 The Maysara Project

The Government of Jordan and the Canadian International Development Agency (CIDA) have identified the community of Maysara, Jordan, as the site for a pilot duckweed-based wastewater treatment facility. The system will incorporate two UASB reactors (see section 8.4.1) as the primary treatment mechanism. Secondary treatment will occur in duckweed-based treatment channels of approximately 2.5 ha in total water surface area. The treatment facility will also demonstrate the recovery and windrow composting of organic solid in an integrated system to recovery organic resources. The project is expected to provide an example for community and private sector involvement in waste management. This facility will be designed to demonstrate that integrated waste management can pay for itself and can be an attractive community amenity.

This project will contribute to an overall decrease in environmental degradation in the vicinity of the Jordan River, as well as recovering operation and maintenance costs through the sale of value-added products produced on the site. The design phase will be undertaken by a CIDA funded team of Canadian and Jordanian engineers and scientists. Construction is expected to begin in early 1999.

The main objectives of the Maysara Project are to:

- ? receive trucked septage and solid waste materials from surrounding communities in the lower portion of the rift valley;
- ? test and demonstrate anaerobic digester (UASB) technology for primary wastewater treatment in combination with a duckweed-based secondary treatment system designed to recover nutrient resources from the effluent.
- ? use treated effluent for irrigation in an environmentally safe sub-surface system to produce terrestrial crops (fodder grasses, trees, and ornamental plants); and,
- ? reuse the recovered duckweed as fodder in the production of poultry, sheep and possibly squab, and; provide an example for community and private sector involvement in a facility designed to demonstrate that integrated waste management can pay for itself and become an attractive community amenity.

9.7 Community-Based Wastewater Treatment - Castor, Senegal

The use of water hyacinth in wastewater treatment is an age old technique utilised over 1,000 years ago in Sudan and is being re-visited today in this system (Malick and Diallo, 1997). In Castor, Senegal, the local NGO, ENDA-Tiers Monde, has built a wastewater collection and treatment system serving most of the communities inhabitants. The project has been successful in gaining support from community members, creating employment opportunities and treating wastewater to a standard high enough to use it directly for the production of food. The system consists of a grease trap, two septic tanks, followed by a small-bore sewage system. The sewage enters a large decanting tank/sedimentation basin, that gets covered by a sludge blanket where most of the sludge is retained. From this point, the secondary effluent flows to a series of 4 aerobic concrete tanks. The tanks are approximately 1 metre. deep and are narrowly designed to prevent wind from layering the plants to one side of the ponds. Water hyacinth/water lettuce (*pistia stratiotes*) comprise the active wastewater treatment at this point in the process. As water passes from tank to tank, the effluent quality is progressively increased. Effluents recovered from the process are being used to irrigate bananas, apples, papaya, peppers, corn, zucchini, okra and a variety of other vegetables. Additionally, a number of tree species are raised on treated effluents recovered from this system. The water hyacinth biomass produced though the treatment process are harvested regularly. This biomass is formed into compost for use in local market gardens (Malick and Diallo, 1997; Mougeot, IDRC Trip Report May 1998).

9.8 Wastewater Stabilisation Ponds

Wastewater stabilisation ponds are large man-made basins into which wastewater flows and from which high quality treated effluent can be produced after a retention time of days - as opposed to hours in conventional treatment processes (Mara and Pearson, 1998). Wastewater stabilisation ponds (WSPs) offer a low-cost method for the treatment of domestic wastewater. The principles behind their operation are simple and make this technology appropriate for the developing world because construction and operational costs are low and they place no strain on technical resources or labour (WHO, 1987). They represent an immediate irrigation resource for semi-arid regions and are characterised as simple to operate low-cost, high efficiency and are, therefore, a technology of choice for many developing world situations (WHO, 1987; Yanez and Pescod, 1988; Hosetti and Frost, 1995; Mara and Pearson, 1998).

WSPs function through natural forces (sun, wind, gravity, and biological activity) acting on the treatment process, allowing low-cost treatment and providing a much greater removal of pathogens than most conventional treatment processes (Mara and Cairncross, 1989; Bartone, 1991). Dubusk *et al.* (1989) attribute coliform reductions in WSPs to high wastewater pH and ultraviolet radiation, making them especially attractive for Mediterranean regions. WSPs are not energy or capital intensive and allow for a high degree removal of pathogenic organisms.

Several WSP variations exist. These include: i) **Facultative Treatment Ponds** which are the simplest of all WSPs and consist of large shallow ponds designed to retain and treat the wastewater for a period of several days. There are two types of facultative ponds: primary facultative ponds receive raw wastewater, and secondary facultative ponds receive settled wastewater. They are designed for BOD removal on the basis of low surface loading in the range of 100-400 kg BOD/ha/d (Mara and Pearson, 1998); ii) **Anaerobic Treatment Ponds** are deep ponds devoid of dissolved oxygen where anaerobic bacteria break down the organic matter, including pathogenic components such as viruses, bacteria, helminth and ascaris eggs. Their main function is BOD removal. Anaerobic pond systems can receive organic loads usually in the range of >100 g BOD/m³/day, equivalent to >3000 kg/ha/d for a depth of 3 m (Mara and Pearson, 1998), and; iii) **Aerated Facultative Ponds** are constructed like facultative ponds except that they are small in surface area because they can be constructed deeper and the retention time required for organic removal is less. Oxygen is supplied by mechanical aerators which increases treatment efficiency and reduces land requirements. However, the power input is sufficient only for diffusing oxygen into the pond and not for mixing the contents.

Bartone (1991) has stated that for hot climates, a minimum 25-day, 5-cell WSP system allows for almost unrestricted irrigation and that restricted irrigation requires a 2-pond, 10-day detention time for adequate pathogen destruction. Removals of BOD greater than 90%, nitrogen removal of 70-90%, and total phosphorous removals of 30-45% are easily achievable in a series of well-designed ponds (Mara and Pearson, 1998). WSPs can attain a 99.999% faecal coliform reduction when operated in parallel, and are capable of attaining a 100% removal of helminths, thus facilitating the recovery of the wastewater for agriculture in both restricted and unrestricted irrigation (WHO, 1987; Mara and Pearson, 1998). Wastewater stabilisation ponds are highly effective in warm tropical climates with full-sunlight conditions, such as the Mediterranean region. The greatest pathogen reductions occur during the warm months which coincide with irrigation season. During these times, effluent standards that meet unrestricted irrigation are easily attained (Ghrabi *et al.*, 1993; Mara and Pearson, 1998).

9.9 Advanced Treatment

Waste stabilisation ponds often have high concentrations of TSS in the effluent, which may or may not be desirable depending on the irrigation delivery method. For instance, closed-conduit irrigation systems, (*e.g.*, sprinklers, micro-sprinklers, and drip irrigation systems) are efficient delivery methods, in terms of minimising evaporation and water loss through over watering, but are prone to clogging when effluents containing high TSS are used (Hillel, 1987; Bartone, 1991). Several polishing options are feasible to use in combination with WSPs to upgrade pond effluents, thereby increasing the options for effluent reuse. Middlebrooks (1995) suggests that many low-cost methods exist for polishing WSP effluent, which include intermittent sand filtration, rock filters and constructed wetlands.

Rock filters, when used in conjunction with WSPs, have been shown to upgrade WSP effluent. Research at a pilot-scale rock filter demonstration conducted at the Assamra WSPs in Jordan showed that effluent content reductions could be reduced greatly. TSS and BOD were reduced by 60%, TFCC by a maximum of 94% and T-P by 46% at a loading rate of 0.33-0.044 kgTSS/m³ (Saidam, Ramadan and Butler, 1995). Wetland-based systems have also been shown to upgrade WSP effluent. Water hyacinth and duckweed systems inhibit the growth of algae by preventing sunlight from reaching the water column. Constructed wetland systems are able to remove a variety of contaminants, including the algae. If high levels of TSS are not an issue in an irrigation scheme and there is no risk of clogging irrigation equipment, high TSS may be advantageous as they will add organic matter to the soil matrix.

The disadvantages of the WSPs are that large land areas are required and that their construction may only be feasible when land values are low (Hosetti and Frost, 1995). WSP lose their comparative cost advantage over mechanised treatment systems when land prices are greater than US\$ 15-20/m² (IBRD Workshop, 1993; Veenstra and Alaerts, 1996; Yu, *et al.*, 1997). However, Mara and Pearson (1998) contend that even at high land costs, WSPs are often the cheapest option and the question is: “do you pay for the required land area up front or for continuously high consumption of electricity in the future?” Often, municipalities can consider WSPs to be an investment in real-estate (Mara and Pearson, 1998).

9.10 Recent Advances in Wastewater Stabilisation Ponds

9.10.1 Stabilisation ponds and supporting growth media

Recently, a demonstration has been implemented that aims to upgrade WSP efficiency, and reduce spatial requirements of WSPs with a supporting growth media (see box 9.4). Although capital investment in the system may increase, the system holds the potential to reduce retention times and decrease spatial requirements of the WSP technology (Yu, *et al.*, 1997).

Box 9.4 Stabilisation Ponds and Supporting Growth Media

“In the pond modified by Zhao and Wang (1996), attached-growth media (AGM) or so-called artificial fibrous carriers were installed. This type of media consists of fine strings of polyvinyl acetate, with specific surface area of 1,236 m²/m³ and cost only US\$ 5/m³. A pilot-scale investigation has been conducted by them, using three ponds with working dimensions of 4.0 m in depth, 1.2 m in width and 1.1 m in depth. This study has confirmed that the incorporation of AGM enhanced the performance of conventional SPs by formation of a great number of small stable ecological systems around AGM., being abundant in biospecies from bacteria and algae to protozoa, increasing the biomass concentration, improving the biological distribution. Better removal efficiencies of COD (75.6%), BOD (90.2%) and NH₄-N (68.5%) had been achieved in the SPs with AGM than in the conventional SPs with AGM than in the conventional SPs, although the total HRT of the former had been shortened to 7.5 days.”

source: Zhao and Wang (1996) in, Yu *et al.*, 1997: 197

9.10.2 Advanced integrated ponds systems

Recently developed in California, wastewater treatment and algae production systems called *Advanced Integrated Wastewater Pond Systems* (AIWPS) are potentially feasible for application in the developing world (Oswald, 1990). AIWPS have been described as:

“4-5 m deep facultative pond containing a “digester pit” which functions much like an anaerobic pond but, in this case, within the facultative pond, rather than preceding it. The facultative pond effluent is discharged into a stirred high-rate pond, then into a settling pond to remove most of the algae produced in the high-rate pond, and thence into maturation ponds for biological disinfection. Recirculation of some of the high-rate pond contents back to the surface layers of the facultative pond ensures odourless conditions in the latter” (Mara and Pearson, 1998:17).

As late as 1994, an AIWPS had been planned for domestic human wastewater treatment downstream from Varanasi, India, in collaboration with USAID (Stille, 1998). The Varanasi AIWPS project is currently in the planning stages.

9.10.3 Sheaffer modular reclamation and reuse system

Sheaffer International markets a variation of the AIWPS described in preceding section (9.10.2). The Sheaffer system is described as a *Modular Reclamation and Reuse System* producing no sludge, no odour, and enabling 100% recovery of nutrient rich water for irrigation. The system is comprised of a deep aerated treatment cell, a storage cell, and three moving parts, described as a grinder pump, a compressor/blower, and an irrigation system (Sheaffer International LTD., 1998).

The first stage of the process uses the grinder pump to reduce sewage solids influent and injects it to an anaerobic zone at the bottom of the treatment cell where it undergoes anaerobic reduction for a 14-30 day period. This zone acts as a mesophilic reactor. Solids settle out of the anaerobic zone to the base of the deep cell, and are stored for a time period of 20 to 30 years. The second stage of the process, the compressor/blower, injects air into the treatment cell just above the anaerobic zone to create aerobic conditions at the surface level of the cell. The cells are designed to provide 14-36 days treatment and further reductions of organic materials (Sheaffer International LTD., 1998).

Solid components are broken down into simple organic acids, methane carbon dioxide, sulphide, ammonia, inorganic compounds, and water. The nitrogen, phosphorus, and potassium are dissolved and remain in solution for use in agricultural irrigation (J. Sheaffer, 1998; personal communication, August, 1998).

9.11 Aquaculture

Aquaculture has been practised for thousands of years as a method to manage human waste and to produce fish protein. Numerous studies in this area have been undertaken to define optimal wastewater loads, stocking densities and the associated human health risks associated with wastewater fed aquaculture. Overall, research in sewage-fed aquaculture systems has advanced the combined knowledge developed in relations to these systems (Edwards, 1996). Waste-fed aquaculture is considered safe, in terms of public health and disease risk, if wastewater is treated minimally in stabilisation lagoons before being discharged into fish rearing ponds. One day anaerobic pond treatment followed by 5-day facultative pond treatment is considered adequate treatment for the protection of public health (Mara *et al.*, 1993; Edwards, 1996).

Health risks increase when the efficiency and operational standards of the system are neglected. Public health concerns can be reduced if wastewater for aquaculture rearing ponds contain $<10^3$ coliforms per 100 ml (WHO, 1989). Research continues on waste-fed systems, but results of research related to the health effects of aquaculture are not definitive and no guidelines related to its use have been formulated. Further research is needed in this area (Khouri *et al.*, 1994; Mara and Cairncross, 1989). Edwards (1996), suggests that the use of aquaculture remains well below its potential and has had minimal impact to date on development. Extensive reviews of waste-fed aquaculture are available and will not occur in this report.

Figure 9.6 Fish Harvest -Duckweed-fed

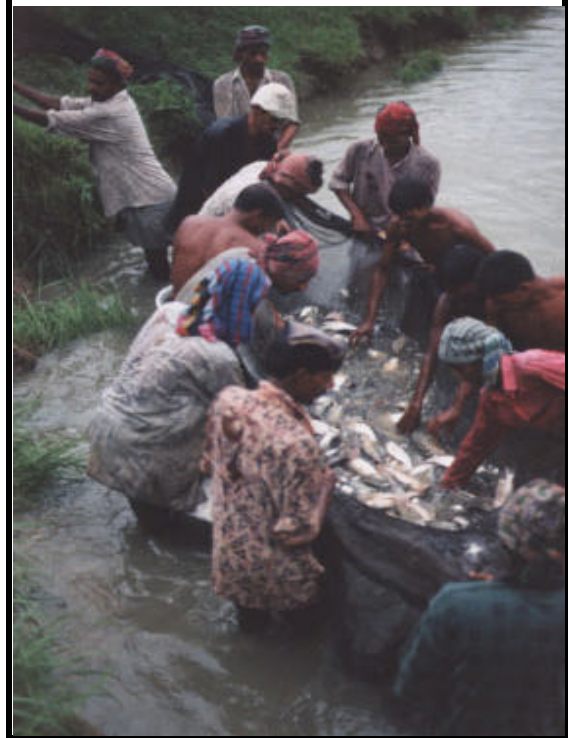

Edwards (1990), suggests that the most effective use of excreta-fed aquaculture to produce fish protein should be a two-stage process. He states that excreta reuse systems such as these are composed of two sequential processes: resource recovery and resource utilisation (see *figure 9.7*). Nutrients are recovered from wastewater through growing "trash" fish, such as tilapia, or plant biomass, such as the aquatic macrophyte duckweed. These products are in turn used as a secondary stage feed stock for the production of larger, high-value fish and crustaceans or as an input for land-based animal husbandry systems (Mara and Cairncross, 1989). The WHO guidelines for the reuse of wastewater in aquaculture suggest that waste-reared fish would probably not contaminate freshwater-reared fish if the trash fish ponds have a faecal coliform count of no more than 10^3 coliform bacteria per 100 ml (Mara and Cairncross, 1989; WHO, 1989).

Shifting waste resources up the food chain incrementally is one alternative in the search for methods to decrease acute public health risks and potentially avoid the sociocultural stigma associated with sewage-fed production systems. Barriers to a wide-scale use of waste-fed aquaculture remain in many parts of the world. The practice is still found in some Asian countries such as Thailand, China, and Vietnam. Furedy (1990) discourages abandonment of these systems and encourages their use in resource poor communities in conjunction with a high level of management for the protection of public health. She also suggests that sewage-fed fish production can be an asset to social development, and research only if the systems are designed as components of community development (Furedy, 1990).

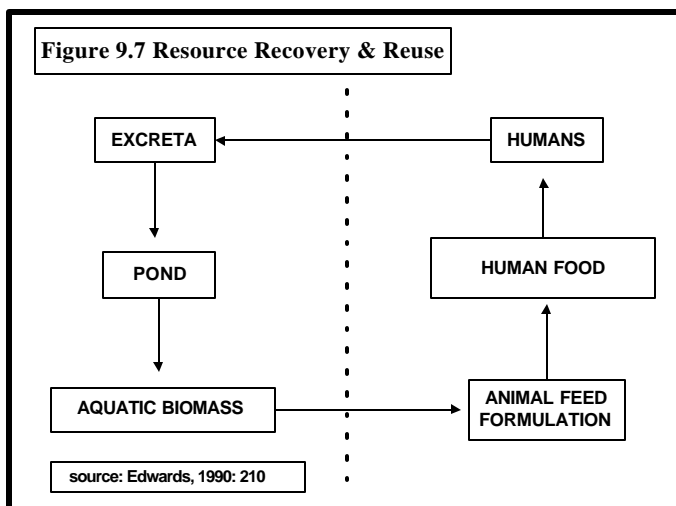

China has a several thousand year old history of using sewage-fed fish production as a part of a larger, and traditional integrated bio-recovery system, and that barriers regarding the use of human and animal waste in food production have apparently been bridged over the generations. However, it has been rumoured that China intends to phase out these systems because of health related issues as Japan and Taiwan have already done (Furedy, 1990).

10.0 SLUDGE MANAGEMENT

10.1 Sludge Reuse in Egyptian Agriculture

Sewerage and wastewater treatment is currently being extended to 13 million Cairo residents under the Greater Cairo Wastewater Project. Sludge production is expected to increase to 0.4 million tonnes/year of dry solids over the next 10 years (Hall, 1996). The *Cairo Sludge Reuse Study* was initiated in 1995 to demonstrate that urban wastewater sludge recycling schemes can be established to link urban waste generation with agricultural production and poor soil reclamation (Hall and Smith, 1997). In addition, because Egyptian farmers are willing to pay for organic soil amendments, there is the opportunity to recover cost (Hall, 1996; Hall and Smith, 1997). The study is being funded by the European Investment Bank.

Box 10.1 Cairo Sludge Reuse Study: rational

"Recycling sludge to agriculture is the only disposal outlet with an identified benefit from the nutrients and organic matter contained in sludge, and its use in agriculture is widely regarded as the best practical environmental option. The fertiliser, and organic matter content of sludge offer resource and energy conservation and maintenance of soil fertility.

Sludge is likely to be particularly valuable for arid countries such as Egypt, where the availability of traditional animal manure is declining, the cost of fertiliser is increasing sharply, and there is an urgent need for horizontal expansion of agriculture into desert areas to feed the rapidly growing population. Consequently, farmers are willing to pay for any form of organic manure, including sludge."

Source: Hall, 1996: 10

10.2 Developments in Natural Sludge De-watering Technology

Water and Sanitation in Developing Countries (SANDEC) has recently undertaken a demonstration project in collaboration with the Asian Institute of Technology (AIT) in Bangkok, Thailand, to manage the sludge from on-site sanitation. The pilot demonstration will test the feasibility of using planted reed beds for sewage de-watering (Heinss and Koottatep, 1998). Developing small scale sludge de-watering systems in or near urban areas would increase the availability of organic inputs for local agriculture and reduce the need to haul sludge out of the urban environment (Strauss, Heinss and Montangero, 1998). The drawback of the system appears to be the large land requirements. The technology may, therefore, only be feasible where land can be secured or where decentralised systems are preferred (Heinss and Koottatep, 1998). However, data has been collected since early 1997, and continues at this time (see figure 10.1).

Heinss and Montangero, 1998). The drawback of the system appears to be the large land requirements. The technology may, therefore, only be feasible where adequate land can be secured or where decentralised systems are preferred (Heinss and Koottatep, 1998).

Data has been collected since early 1997, and the project continues at this time. Overall, this project represents a new approach in using constructed wetlands to treat faecal waste because the sludge has not been stabilised or anaerobically digested prior to aerobically prior to trucking the septage to the demonstrations for dewatering. Heinss and Koottatep (1988) have also stated that sludge that has been adequately stabilised may lend itself better to reed bed dewatering than fresh, unstabilised, public toilet type sludge.

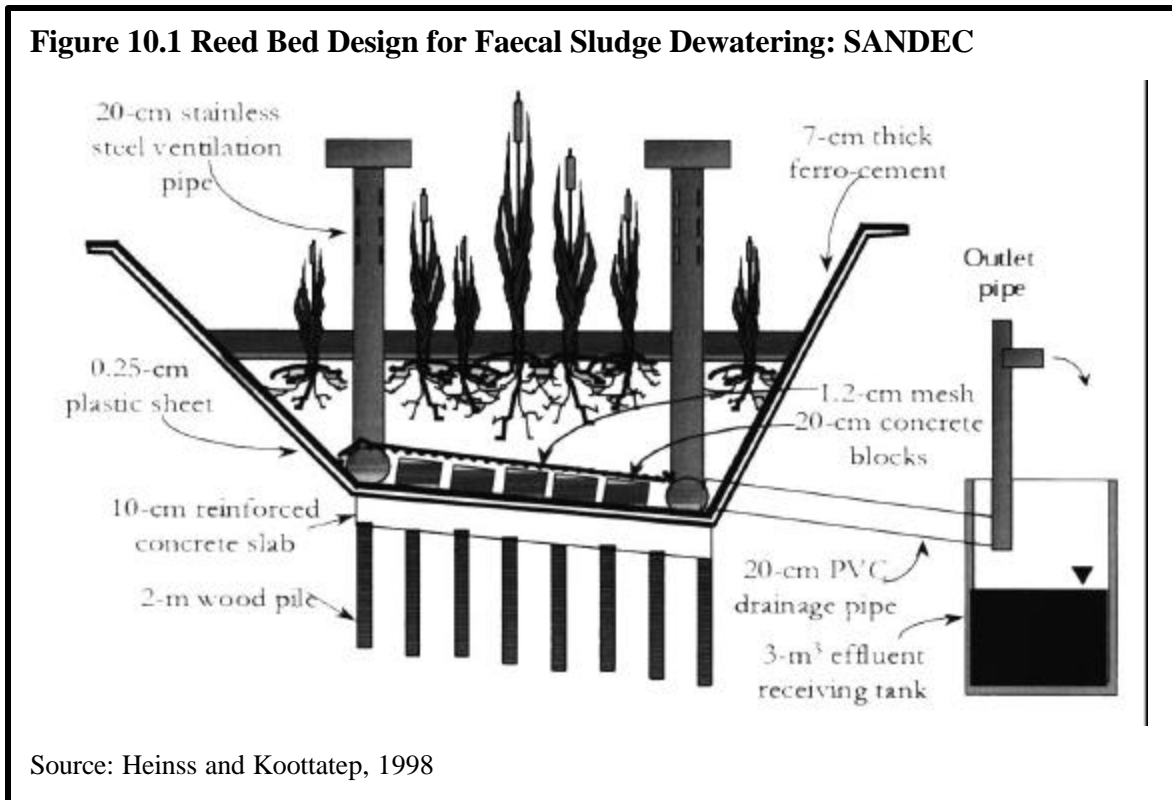

This concludes PART II: Selected Treatment Technologies.

Part III: Conclusions and Recommendations

11.0 CONCLUSIONS and RECOMMENDATIONS

Conclusions:

This report has surveyed a variety of options that may be employed in the treatment, recovery and reuse of wastewater and faecal nutrient resources in urban and peri-urban environments. It is apparent that a variety of options are feasible for use in the developing world and even more apparent that many low-technology options can be mixed and matched for very high efficiencies. Natural treatment technologies are attracting a significant level of interest by environmental managers. Natural treatment technologies are considered viable because of their low capital costs, their ease of maintenance, their potentially longer life-cycles (when compared to electro-mechanical solution) and their ability to recover a variety of resources including: treated effluent for irrigation, organic humus for soil amendment and energy in the form of biogas. In fact, the functional sustainability and longevity of any technology to provide services to the local community can, and should be, directly correlated to the ability of that intervention to recycle precious resources and to enable the production and sale of products that can lead to the recovery of construction and operation costs, while meeting the sanitary needs of the community.

This report examined emergent issues and technological options related to the scale of collection and treatment systems. There is increasing momentum developing behind the notion that recycling loops, from point of generation (e.g., the household) to point of treatment and reuse must be shortened. Additionally, it is imperative that in order to facilitate the reuse of recovered organic nutrients, urban wastewater resources must be differentiated from the industrial wastewater flows that can contaminate valuable wastewater resources. Beck *et al.*, (1994) have noted that although the questions of human waste treatment is a humble one, it may nevertheless, "be undergoing a period of substantial, innovative re-thinking". Beck *et al.* and Boller (1997) have stated, there are two directions emerging at this time. They are: the development and reliance on increasingly mechanised technological options and the consideration of low technology systems that harness natural processes to achieve equal results.

The development and implementation of naturally-based and de-centralised technologies in the urban environment is not without barriers and impediments. For instance, non-mechanised, off-site, treatment technologies are, by their very nature, consumptive in terms of their spatial requirements (e.g. constructed wetlands or wastewater stabilisation ponds) and the price of urban land can rapidly off-set the comparative lower cost of any low-technology alternative.

Affordable, de-centralised on-site or off-site treatment systems are essentially self-help sanitation systems for communities and are often labour intensive. Therefore, the "investment" required by the local community must often be large, although this, in turn, does serve to employ community members. Where a highly integrated wastewater treatment system can be combined with agricultural production, an even larger economy can result from the sanitation scheme.

Based on the preceding literature review contained in this document and the identifications of a definite "momentum" behind the development of natural treatment and resources recovery systems, the following recommendations are presented.

Recommendations:

The following recommendations have been broken down into 2 major groups: *recommendations for research* and *recommendations for action*. Further classifications have also been made where applicable.

Recommendations for Research:

Strategic

Technologies that employ an intermediate distance conveyance schemes based on small-bore sewerage systems that drain to decentralised treatment facilities and can serve the needs of individual catchments and population ranges from hundreds to thousands of users (*e.g.*, UASB reactors, constructed wetlands and biogas reactors).

Technical

Further epidemiological studies must be undertaken regarding the potential for heavy metals to accumulate in and contaminate food products (plant and animal protein) that are produced when nutrients and water recovered from wastewater resources are shifted up the food chain in agricultural production.

Invariably, there will be an insect pest that will manifest in relation to the duckweed crop and attention should be directed towards rapid identification of the pest and determinations made vis-à-vis a biological, as opposed to, chemical control method.

The characterisation of influent and effluent (physical, chemical and microbiological) is of high importance in demonstration level project activities, specifically heavy metal uptake and pathogen vectors by the duckweed plants, as it could effect human or livestock health.

Technology Development

Technologies that employ on-site level latrine technologies (*e.g.*, composting toilets/reedbeds, upflow anaerobic filtration systems or biogas reactors) that can be used independently by one household or scaled-up in functional capacity to serve the needs of small clusters of adjoining households (*i.e.*, conveyance systems designed to drain individual households, sharing one on-site treatment unit whose cost and maintenance is also shared).

Onsite dry composting latrines should be re-visited in terms of the potential and opportunity that exists to integrate this technology into urban environments. The recent successes in combining composting toilets with reedbed filters is a highly innovative approach that must be explored and further developed.

Research efforts should also concentrate on developing small-scale anaerobic treatment technologies that can be used in confined space urban environments (*e.g.*, biogas reactors, anaerobic upflow filters and the recently developed biogas technology: *tubular polyethylene digesters*).

Intermediate-scale and low-technological options such as anaerobic upflow blankets and duckweed-based lagoon treatment technologies should be explored where the spatial requirements can be met.

The identification of duckweed species that will acclimate well to a variety of Middle Eastern environments and conditions. Identifying indigenous varieties that will thrive in the local environment will be difficult, but doing so would contribute to the resilience and stability of a duckweed-based system to withstand perturbations.

To identify conditions and factors that impede and promote the growth of *duckweed* in the intense heat and extreme UV radiation typical arid environments. This would include identifying stresses imposed on the cropping system and methods and approaches to mitigate these stresses, such as scheduled dunking of the macrophytes and regulation of an optimum water column depth to buffer the water temperature. For instance, low cost shading systems such as trellises composed of palm fronds could be built over the system and used to shade the system from intense heat. Grape vines and hanging vegetables could be cultivated on the trellises to optimise the spatial production of the system. Shading the system would also act to decrease evaporation.

Environmental impacts of any proposed system must be considered. A major research gap is the identification and construction of low-cost impermeable liners; perhaps bentonite clay could be considered (if locally available) opposed to geo-textile liners that would need to be imported. In addition to aquifer protection, hydraulic retention of the water resource would be a major concern in reducing evaporation and water loss in arid environment.

Economic

Emphasis should be placed on developing demonstration level projects that will validate low-technological innovations that are powered or “driven” by natural processes. These pilots should include a cost-benefit analysis component resulting in data that can be used to inform and educate planners and municipal-level officials regarding the potential benefits of low technology and naturally-based treatment and recovery systems.

That a cost-benefit analysis of the system should be undertaken by the economist involved in the project as supplemental water will, most likely, have to be purchased to maintain an adequate water column depth for the system (*e.g.*, greywater and blackwater combined may not be adequate).

Sociocultural

Research should be directed toward the development of methods to mobilise local community groups in self-help sanitation schemes centred around key technologies.

Increasing efforts should concentrate on the sociocultural aspects of reusing human derived wastewater in the production of food products (plant and animal protein) in target geographical areas.

Composting toilets technology need to be accompanied by an agricultural component that acts as the "sink" to assimilate the stabilised nutrient resources. Therefore, methodologies should be sought that will enable the successful integration of dry sanitation technologies with urban agricultural schemes.

The sociocultural, institutional and local community related factors that impede or promote the acceptance of a domestic wastewater treatment and reuse scheme for agricultural end-use (potentially human food) will need attention. Project activities to promote involvement of these groups should be defined. A description of the socioeconomic conditions and an analysis of local markets where produced goods may be sold should undertaken when integrated technologies are considered.

Recommendations for Action:

Strategic

Increasing emphasis should be placed on assisting local and municipal level planning departments to promote sanitation schemes that allow for the decentralisation of wastewater treatment at the household or local catchment level, thus decreasing the size of wastewater recycling loops.

Increasing emphasis must be directed towards the differentiation of wastewater flows in the urban environment. Domestic and industrial effluents must be segregated in order to facilitate the reuse of recovered organic nutrients contained in domestic wastewater.

Efforts should be directed towards the promotion of multiple and strategically located treatment facilities (nodes) that enable the treatment of wastewater and the recovery of resources. These facilities may also serve as distribution nodes for the nutrient and water resources that are recovered.

Technical

A suggestion is made to integrated several of the basic Permaculture precepts the design of proposed wastewater treatment and resource recovery schemes where agricultural production is a central component. Two books are of note to aid in this research: Bill Mollison: *Introduction to Permaculture* and *Permaculture: A Designers' Manual*.

Collaboration

Several potential collaborators have been suggested in Annex IV.

This concludes Part III: Conclusions and Recommendations.

References

- Ahmad, A. (1990). Impact of human activities on marine environment and guidelines for its management: Environmentalist viewpoints. In V. Agrawal and P. Das (Eds.), *Recent Trends In Limnology*, pp: 49-60.
- Alaerts, G. J., Veenstra, S., Bentvelsen, M. & van Duijl, L. A. (1993). Feasibility of anaerobic sewage treatment in sanitation strategies in developing countries. *Water, Science & Technology*, **27** (1):179-186.
- Alaerts, G. J., Rahman Mahbubar, M. & Kelderman, P. (1996). Performance analysis of a full-scale duckweed covered sewage lagoon. *Water Resources Development*, **30** (4): 843-852.
- Angelakis, A., Asano, T., Diamadopoulos, E. & Tchobanoglous, G. (Eds.). (1995). Wastewater reclamation and reuse. *Proceedings of the international symposium on wastewater reclamation and reuse*. Iraklio, Greece. October 17-20, pp: 10.
- Appasamy, P. & Lundqvist, J. (1993). Water supply and waste disposal strategies for Madras. *Ambio*, **22** (7): 442-448.
- Asano, T. & Levine, A. D. (1996). Wastewater reclamation, recycling, and reuse: Past, present, and future. *Water, Science & Technology*, **33** (10): 1-14.
- Asano, T., Maeda, M. & Takaki, M. (1996). Wastewater reclamation and reuse in Japan: Overview and implementation examples. *Water, Science & Technology*, **34** (11): 219-226.
- Bahri, A. & Brissaud, F. (1996). Water reuse in Tunisia: Assessing a national policy. *Water, Science & Technology*, **33** (10): 87 - 94.
- Barnard, G. & Kristoferson, L. (1985). *Agricultural residues as fuels in the third world*. London: Earthscan, IIED.
- Bartone, C. R. (1991). International perspective on water resources management and wastewater reuse - appropriate technologies. *Water, Science & Technology*, **23**: 2039-2047.
- Beck, M. B., Chen, J., Saul, A. J. & Butler, D. (1994). Urban drainage in the 21st century: Assessment of new technology on the basis of global material flows. *Water, Science & Technology*, **30** (2), pp: 1-12.
- Black, M. (1994). *Mega - slums: The coming sanitary crisis*. London: WaterAid.
- Blumenthal, U. (1988). Generalized model of the reduction in health risk associated with different control measures for the use of human wastes. *IRCWD News*, **24/25**: 13-18.
- Bo, L.Ting-xin, D, Zhi-ping, Llou-wei, M. Zhu-xuen, W & An-xiu, Y. (1993). Use of night soil in agriculture and fish farming. *World Health Forum*, **14**: 67-70.
- Boller, M. (1997). Small wastewater treatment plants - A challenge to wastewater engineers. *Water, Science & Technology*, **35** (6): 1-12.
- Bonomo, L., Pastorelli, G. & Zambon, N. (1997). Advantages and limitations of duckweed-based wastewater treatment systems. *Water Science & Technology*, **35**(5): 239-146.
- Botero, R. & Preston, T. (1986). Low-cost biodigester for production of fuel and fertilizer from manure (Spanish). *Manuscripto ineditado CIPAV*. Cali, Colombia, pp: 1-20.
- Bouwer, H. (1991). Ground water recharge with sewage effluent. *Water, Science & Technology*, **23**: 2099-2108.
- Bouwer, H. (1993a). From sewage to zero discharge. *European Water Pollution Control*, **3**(1): 9-16.

- Bouwer, H. (1993b). Urban and agricultural competition for water, and water reuse. *Water Resources Development*, **9** (1): 13-25.
- Briscoe, J. & Steer, A. (1993). New Approaches to sanitation - A process of structural learning. *Ambio*, **22** (7), pp: 456- 459.
- Brix, H. & Schierup, H. (1989). The use of aquatic Macrophytes in water-pollution control. *Ambio*, **18** (2), pp: 100-107.
- Brix, H. (1994). Use of constructed wetlands in water pollution control: Historical development, present status, and future perspectives. *Water, Science & Technology*, **30** (8): 209-223.
- Bui Xuan An., Ngo Van Man, Duong Nguyen Khang, Nguyen Duc Anh & Preston, T. (1995). Installation and performance of low-cost polyethylene tube biodigesters on small-scale farms in Vietnam. *Proceedings of the national seminar-workshop in sustainable livestock production on local feed resources*. Agric. Pub. House: Ho Chi Minh, pp: 95-103.
- Bui Xuan An., Preston, T. & Dolberg, F. (1997). The introduction of low-cost polyethylene tube biodigesters on small scale farms in Vietnam. *Livestock Research for Rural Development*, **9** (2): 27-35.
- Caceres, A. (1988). *Dissemination of dry latrines in Guatemala*. Centre for Meso-American studies on appropriate technology.
- Cairncross, S. & Feacham, R. (1993). *Environmental health engineering in the tropics*. Chichester: Wiley.
- Chan, G. L. (1993). Aquaculture, ecological engineering: Lessons from China. *Ambio*, **22** (7): 491-494.
- Chan, G. (1996). Mandate for multi-disciplinary action. . In A. Balkema, H. Aalbers and E. Heijndermans (Eds.), *Workshop on sustainable municipal waste water treatment systems*, pp. 102-127. ETC in co-operation with WASTE. Leusdan, the Netherlands. 12-14 November 1996.
- Chavez, A. (1987). Design construction and conventional structure of the DAFF Latrine. Centre for Mesoamerican studies on appropriate technology. *Proceedings in first national workshop on dry alkaline family fertilizer latrines*. Guatemala. 22-26 June 1987.
- Chawathe, S. D. & Kantawala, D. (1987). Reuse of water in city planning. *Water Supply*, **15** (1): 17-23.
- Chen, H. (1992). Combining bio-fixed film and aquatic plant for small wastewater treatment with aquatic plant for small wastewater treatment with land restriction. (*M.S. Thesis, University of Hawaii, Department of Agricultural Engineering*), pp: 155.
- Chen, R. (1997). Livestock-biogas-fruit systems in South China. *Ecological Engineering*, **8**: 19-29.
- Cointreau, S. (1982). *Environmental management of urban solid wastes in developing countries*. Washington, D.C.: The World Bank.
- Cointreau, S., Gunnerson, C., Huls, J. & Seldman, N. (1984). *Recycling from municipal refuse: A state-of-the-art review and annotated bibliography*. (Technical Paper Number No. 30). Washington, D.C.: World Bank.
- Del Porto, D. (1998). *Internet Conference on Integrated Bio-Systems*. Institute of Advanced Studies, United Nations University UNESCO. Available: <http://www.ias.unu.edu/proceedings/icibs/>.
- Denny, P. (1997). Implementation of constructed wetlands in developing countries. *Water, Science & Technology*, **35** (5): 27-34.
- Di, C. (1993). Characteristics and role of good cycle systems for rural biogas in Jiangsu Province (Chinese). *China Biogas*, **11** (2): 51-53.

- Doelle, H. W. (1998). Socioeconomic microbial process strategies for a sustainable development using environmentally clean technologies. Renewable resources: Sagopalm. In E. L. Foo and T. Della Senta (Eds.), *Proceedings of the internet conference on integrated bio-systems*. Available: <http://www.ias.unu.edu/proceedings/icibs>.
- Dubusk, T. Reddy, K., Hayes, D. & Schwegler, B. (1989). Performance of pilot scale water hyacinth. *Journal Water Pollution Control Federation (JWPCF)*, **61**: 1217-1224.
- Eco-Tek Wastewater Treatments Inc. (1998). Promotional literature. Langley, B.C. Canada.
- Edwards, P. (1985). *Aquaculture: A component of low cost sanitation*. (World Bank Technical Paper No. 36). Washington, D.C.: The World Bank.
- Edwards, P. (1990). An alternative excreta-reuse strategy for aquaculture: the production of high protein animal feed. In P. Edwards and R. Pullin (Eds.). (1990). Wastewater-fed aquaculture. *Proceedings of the international seminar on wastewater reclamation and reuse for aquaculture*. Calcutta, India. Environmental Sanitation Information Centre and the Asian Institute of Technology, Bangkok, Thailand. 6-9 December, 1988 pp. 209-221.
- Edwards, P. (1992). Reuse of human wastes in aquaculture: A technical review. *UNDP-World Bank water and sanitation program*. Washington, D.C.: The World Bank.
- Edwards, P. (1996). Wastewater-fed aquaculture systems: Status and prospects. *Naga The ICLARM Quarterly*: 33-35.
- Elmendorf, M. (1992). *Centre file: 88-0104 Integral system for recycling organic waste, Mexico* (trip report to Mexico). Ottawa: International Development Research Centre.
- Fahm, L. (1980). *The waste of nations: The economic utilisation of human waste in agriculture*. Montclair, New Jersey: Allanheld, Osmun & Co. Publishers, Inc.
- Farrell, M. (1996). Purifying wastewater in green houses. *BioCycle*, January, 1996.
- Fittschen, I. & Niemczynowicz, J. (1997). Experiences with dry sanitation and greywater treatment in the Ecovillage Toarp, Sweden. *Water, Science & Technology*, **35** (9): 161-170.
- Foo, E. L. & Della Senta, T. (1998). *Internet conference on integrated bio-systems (ICIBS)*. Available: <http://www.ias.unu.edu/proceedings/icibs>.
- Food and Agriculture Organization (FAO). (January, 1999). Biogas Technology: A Training Manual for Extension. Consolidated Management Services - Kathmandu, 1996. Available: <http://www.fao.org/sd/EGdirect/EGre0021.htm>.
- Forget, G. (1992). *Health and the environment: A people-centered strategy*. Ottawa: International Development and Research Centre.
- Frijns, J. & Jansen, M. (1996). Institutional requirements for appropriate wastewater treatment systems. In A. Balkema, H. Aalbers and E. Heijndermans (Eds.), *Workshop on sustainable municipal waste water treatment systems*, pp: 54-66. Leusdan, the Netherlands. ETC in co-operation with WASTE. 12-14 November, 1996.
- Furedy, C. & Ghosh, D. (1984). Resource - conserving traditions and waste disposal: The garbage farms and sewage -fed fisheries of Calcutta. *Conservation & Recycling*, **7** (2-4): 159-165.
- Furedy, C. (1990). Social aspects of human excreta reuse: Implications for aquaculture projects in Asia. In P. Edwards and R. S. V. Pullin (Eds.), *Wastewater-fed aquaculture*, pp: 251-266. Proceedings of the international seminar on wastewater reclamation and reuse for aquaculture, Calcutta, India. Environmental Sanitation Information Centre, Asian Institute of Technology. Bangkok, Thailand. 6-9 December, 1988.

- Furedy, C., Maclaren, V. & Whitney, J. (in press). *Waste reuse for food production in Asian cities: Health and economic perspectives.*
- Gardner, G. (1998). *Recycling organic waste: From urban pollutant to farm resource.* Worldwatch Paper 135. State of the world 1998: A Worldwatch institute report on progress toward a sustainable society. New York: W.W. Norton & Company.
- Garuti, G., Dohanyos, M. & Tilche, A. (1992). Anaerobic - aerobic wastewater treatment system suitable for variable population in coastal areas: The Ananox[®] process. *Water, Science & Technology*, 25 (12): 185-195.
- Ghosh, D. (1991). Ecosystems approach to low-cost sanitation in India: Where the people know better. In C. Etnier and B. Guterstam (Eds), *Ecological engineering for wastewater treatment*, pp: 63-79. Gothenburg, Sweden: Bokskogen.
- Ghrabi, A., Ferchichi, M. & Drakides, C. (1993). *Water, Science & Technology*, 28 (10): 193-199.
- Giles, H. & Brown, B. (1997). "And not a drop to drink". Water and sanitation services in the developing world. *Geography*, 82 (2): 97-109.
- Grau, P. (1994). What Next?. *Water Quality International*, 4: 29-32
- Green, M. B. & Upton, J. (1995). Constructed reed beds: Appropriate technology for small communities. *Water, Science & Technology*, 32 (3): 339-348.
- GreenGold Corporation (1998). Available: <http://www.ntrnet.net/~skilli/NWW.htm>.
- Gunnerson, C. G. (1982). Overview of UNDP/World Bank research and development in integrated systems for resource recovery. *Recycling International*.
- Guterstam, B. & Todd, J. (1990). Ecological engineering for wastewater treatment and its application in New England and Sweden. *Ambio*, 19: 173-175.
- Haberl, R., Perfler, R. & Mayer, H. (1995). Constructed wetlands in Europe. *Water, Science & Technology*, 32 (3): 305-315.
- Hall, J. (1996). Cairo sludge reuse study. *World Water and Environmental Engineering*, June, p: 10.
- Hall, J. & Smith, S. (1997). Cairo sludge disposal study. *Journal Chartered Institution of Water and Environmental Management (JCIWEM)*. October, 373-376.
- Hardroy, J. & Satterthwaite, D. (1997). Health and environment and urban poor. In G. Shahi, B. Levy, & T. Kjellström and R. Lawrence (Eds.), *International perspectives on environment, development and health: Toward a sustainable world*, pp: 123-162. Springer Publishing Company, New York.
- Harremöes, P. (1997). Integrated water and waste management. *Water, Science & Technology*, 35 (9): 11-20.
- Harsch, J. (1996, October). *World engineering partnership for sustainable development*. Available: <http://www.ciesin.org:9000/summary.html>.
- Hauser, J. R. (1984). Use of water hyacinth aquatic treatment systems for ammonia control and effluent polishing. *Research Journal of the Water Pollution Control Federation*, 56 (3): 219-224.
- Heinss, U. & Kopottatop, T. (1998). *Use of reed beds for faecal sludge dewatering: A synopsis of reviewed literature and interim results of pilot investigations with septage treatment in Bangkok, Thailand.* Swiss Federation Institute for Environmental Science and Technology (EAWAG), Water and Sanitation in Developing Countries (SANDEC) and Asian Institute of Technology (AIT).
- Henderson, J. P. (1998, October). Available: <http://www.interchg.ubc.ca/johnph/digester.html>.

- Hillel, D. (1987). *The efficient use of water in irrigation; principles and practice for improving irrigation in arid and semiarid regions*. (World Bank Technical Paper No. 64). Washington, D.C..
- Hobson, P. & Wheatley, A. (1993) *Anaerobic digestion- modern theory and practice*. London: Elsevier Applied Science.
- Hong, J. (1993). Common applications for the operation rules of fermentation technology of household biogas digester (Chinese). *China Biogas*, **11**(2): 25-26.
- Hosetti, B. B. & Frost, S. (1995). A review of sustainable value of effluents and sludges from waste water stabilization ponds. *Ecological Engineering*, **5**: 421-431.
- Tinker, I. (1994). *Cities feeding people: An examination of urban agriculture in East Africa, vii-xiv*. Ottawa, Canada: International Development Research Centre.
- Information and Advisory Service on Appropriate Technology (ISAT). (1998, March). Available: http://gate.gtz.de/isat/at_info/biogas/AT_biogas.html.
- Internet Conference on Integrated Bio-Systems (ICIBS). (1998). Available: <http://www.ias.unu.edu/proceedings/icibs>.
- IRBD (International Bank for Reconstruction and Development). (1993). Workshop on UASB technology for sewage treatment. *DHV and Haskoning Consultants*, Netherlands as prepared for Word Bank.
- IRCWD. (International Resource Centre for Waste Disposal) (1985). *Health aspects of wastewater and excreta use in agriculture and aquaculture--The Engelberg Report*. Dübendorf, Switzerland: International Reference Centre for Waste Disposal.
- Israel Advisory committee on Wastewater Reuse of Agricultural Irrigation. (1978) The Ministry of Health, Jerusalem, pp: 1-9.
- Jewell, W. (1996). Resource-recovery wastewater treatments with biological systems. In A. Balkema, H. Aalbers and E. Heijndermans (Eds.), *Workshop on sustainable municipal waste water treatment systems*, pp: 67-101. ETC in co-operation with WASTE. Leusdan, the Netherlands. 12-14 November, 1996..
- Jimenez-Cisneros, B. & Chavez-Meija, A. (1997). Treatment of Mexico City wastewater for irrigation purposes. *Environmental Technology*, **18**: 721-730.
- Kanarek, A. & Michail, M. (1996). Groundwater recharge with municipal effluent: Dan Region reclamation project, Israel. *Water Science & Technology*, **34**(11): 227-233.
- Kayaya, M. (1997). Zambia promotes biogas as a source of energy. *Panafrican New Agency*. August 4, 1997. Available: <http://www.africanews.org/PANA/environment/19970804/feat3.html>.
- Khoury, N., Kalbermatten, J. M., & Bartone, C. (1994). The reuse of wastewater in agriculture: A guide for planners. *UNDP - World Bank Water and Sanitation Program*. Washington, DC.: The World Bank.
- Kim, S. (1980). *Waste reuse in Korea: Composting by using the municipal refuse and nightsoil*. (Final Report). Ottawa, Canada: International Development Research Centre.
- Kumar, P. & Garde, R. J. (1989). Potentials of water hyacinth for sewage treatment. *Research Journal of the Water Pollution Control Federation*, **61** (11/12): 1702-1706.
- Lance, J. C., Rice, R. C. & Gilbert, R. G. (1980). Renovation of sewage water by soil columns flooded with primary effluent. *Journal of Water Pollution Control Federation*, **52**(2): 381-388.
- Lardinios, I. & van del Klundert, A. (1993). *Organic waste: Options for small-scale resource recovery (Urban solid waste series 1)*. Gouda, the Netherlands: Tool, Amsterdam WASTE Consultants.

- Leeflang, S. (1996). Small scale systems for wastewater treatment and composting toilets in countryside towns. In A. Balkema, H. Aalbers and E. Heijndermans(Eds.), *Workshop on sustainable municipal waste water treatment systems*, pp: 54-57. Leusdan, the Netherlands. ETC in co-operation with WASTE. 12-14 November, 1996.
- Leitman, J. (1994). *Rapid Urban Environmental Assessment: Lessons from cities in the developing world. Vols. I: Methodology and Preliminary Findings* (Urban Management program Discussion Paper; no. 14). Washington, D.C.: World Bank.
- Lettinga, G., Roersma, R., Grin, P., de Zeeuw, W., Pol, L., van Velsen, L., Hobna, S. & Zeeman, G. (1981). Anaerobic treatment of sewerage and low strength waste waters. *Proceedings of the second international symposium on aerobic digestion*. Travemunde, Germany. pp: 271-292.
- Lettinga, G. & Hulsffof, P. (1991). UASB-process design for various types of wastewaters. *Water Science & Technology*, 24(8): 87-107.
- Lewcock, C. (1995). Farmer use of urban waste in Kano. *Habitat International*, 19 (2): 225-234.
- Ma, S. & Yan, J. (1989). Ecological engineering for treatment and utilization of wastewater. In W. Mitsch and S. Jorgensen (Eds.), *Ecological engineering: An introduction to ecotechnology*, pp: 185 - 217. New York: J. Wiley & Sons, Inc.
- Malick, G. & Diallo, F. (1997). Community participation in the management of the urban environment in Rufisque (Senegal). *Environment and Urbanization*, 9 (1).
- Mandi, L. (1994). Marrakesh wastewater purification experiment using vascular aquatic plants *Eichhornia Crassipes* and *Lemna Gibba*. *Water, Science & Technology*, 29 (4): 283-287.
- Mara, D. & Cairncross, S. (1989). *Guidelines for the safe use of wastewater and excreta in agriculture and aquaculture*. Geneva: United Nations Environmental Programme/World Health Organization.
- Mara, D., Edwards, P., Clark, D. & Mills, S. (1993). A rational approach to the design of wastewater-fed fishponds. *Water Resource*, 24(12): 1797-1799.
- Mara, D. (Ed.). (1996). *Low cost sewerage*. New York: John Wiley and Sons.
- Mara, D. & Pearson, H. (1998). *Design manual for waste stabilization ponds in Mediterranean countries. European investment bank*. Leeds, England: Lagoon Technology International Ltd.
- Marchaim, U. (1992). Biogas processes for sustainable development. *FAO Bulletin No. 95*. Rome: FAO.
- Marks, R. F. (1993). Appropriate sanitation options for Southern Africa. *Water, Science & Technology*, 27 (1): 1-10.
- McCarty, P. L. (1981). One hundred years of anaerobic treatment. *Proceedings of the second international symposium on aerobic digestion*. Travemunde, Germany. pp: 3-22.
- McCarty, P. L. (1985). Historical trends in the treatment of diluted wastewaters. In M. J. S. Switzenbaum (Ed.), *Proceedings of the seminar/workshop anaerobic treatment of sewage*. 27-29 June, Amherst. pp: 3-16.
- Middlebrooks, E. J. (1995). Upgrading pond effluents: An overview. *Water, Science & Technology*, 31 (12): 353-368.
- Mills, R. A. & Asano, T. (1996). A retrospective assessment of water reclamation projects. *Water, Science & Technology*, 33 (10): 59-70.
- Mitsch, W. J. (1977). Energy conservation through interface ecosystems. *Proceedings of the international conference on energy use and management*. Oxford, England: Pergamon Press, pp: 875-881.

- Mitsch, W., & Jorgensen, S. (1989). Introduction to ecological engineering. In W. Mitsch and S. Jorgensen (Eds.), *Ecological engineering: An introduction to ecotechnology*, pp: 3-12. New York: J. Wiley & Sons, Inc.
- Mitsch, W. J. (1991). Ecological engineering: the roots and rationale of a new ecological paradigm. In C. Etnier and B. Guterstam (Eds), *Ecological engineering for wastewater treatment*, pp: 110-120. Gothenburg, Sweden: Bokskogen.
- Moog, F. A., Avilla, H. F., Agpaoa, E. V., Valenzuela, F. G. & Concepcion, F. C. (1997). Promotion and utilisation of polyethylene biodigester in smallhold farming systems in the Philippines. *Livestock Research for Rural Development*, 9(2).
- Muller, M. & Rijnsburger, J. (1994). MAPET: Manual pit latrine emptying technology project: A neighbourhood-based pit emptying service with locally manufactured hand pump equipment for Dar es Salaam, Tanzania. *WASTE Project Report*. Gouda, the Netherlands.
- Munasinghe, M. (1992). Water supply and environmental management. In C. W. Howe (Ed.), *Studies in water policy and management*, pp: 163 - 195. San Francisco: Westview Press.
- National Research Council (NRC). (1981). *Food, fuel and fertiliser from organic wastes*. Washington, D.C.: National Academy Press.
- Nazir, M. (1991). Biogas plants construction technology for rural areas. *Bioresource Technology*, 35: 283-289.
- Ngo, V. (1985). Boosting pond performance with aquaculture. *Operation Forum*, 4: 20.
- Niemczynowicz, J. (1993). New aspects of sewerage and water technology. *Ambio*, 22(7): 449-455.
- Niemczynowicz, J. (1996). Megacities from a water perspective. *Water International*, 21 (4): 198 - 205.
- Niemczynowicz, J. (1997). The Water Profession and Agenda 21. *Water Quality International*, March/April: 9-11.
- Obeng, L. & Wright, F. (1987). *The co-composting of domestic solid and human wastes*. (World Bank Technical Paper No. 57). Washington, D.C.
- Oomen, J. & Schellinkhout, A. (1993). The economic feasibility of the UASB technology, a comparative study on costs. *IBRD workshop on UASB technology for sewage treatment*. Washington, D.C..
- Oron, G. (1990). Economic considerations in wastewater treatment with duckweed for effluent and nitrogen renovation. *Research Journal, WPCF*, 62(5): 692-696.
- Oron, G. (1994). Duckweed culture for wastewater renovation and biomass production. *Agricultural Water Management*, 26: 27-40.
- Oswald, W. J. (1990). Advanced integrated wastewater pond systems. *Proceedings of the ASCE convention: Supplying water and saving the environment for six billion people*. San Francisco, CA., 5-8 Nov, 1990, pp: 73-80.
- Otterpohl, R., Grottker, M. & Lange, J. (1997). Sustainable water and waste management in urban areas. *Water, Science & Technology*, 35(9): 121-133.
- Otterpohl, R., Albold, A. & Oldenburg, M. (1998). Differentiating management resource of water and waste in urban areas. In E. L. Foo and T. Della Senta (Eds), *Internet conference on integrated bio-systems (ICIBS)*. pp: 1-18.

- Panicker, P. V. R. C. & Krishnamoorthi, K. P. (1981). Parasite egg and cyst reduction in oxidation ditches and aerated lagoons. *Water Pollution Control Federation*, **53**: 1413-1419.
- Parr, J. (1996). Toward effective wastewater management in developing countries: some issues. In A. Balkema, H. Aalbers and E. Heijndermans (Eds.), *Workshop on sustainable municipal waste water treatment systems*, pp: 197-200. Leusdan, the Netherlands. ETC in co-operation with WASTE. 12-14 November, 1996.
- Price, T. & Probert, D. (1997). Role of Constructed wetlands in environmentally-sustainable developments. *Applied Energy*, **57** (2/3): 129-174.
- PRISM-Bangladesh. *The PRISM duckweed-based waste water treatment system*. Dhaka, Bangladesh: PRISM literature.
- Qixing, Z., Limei, D. & Bell, R. W. (1996). An integrated plan for town-enterprise reuse and wetland strategy: A case study. *Desalination*, **106**: 439-442.
- Riggle, D. (1996). Anaerobic digestion of MSW and industrial wastewater. *BioCycle*, November.
- Rodríguez, L., Preston, T. & Van Lai, N. (1998). Integrated farming systems for efficient use of local resources. In E. L. Foo and T. Della Senta (Eds.), *Proceedings of the internet conference on integrated bio-systems*. Available: <http://www.ias.unu.edu/proceedings/icibs>.
- Rogers, P. (1998). *Water crisis in the middle east and North Africa*. *Britannica Book of the year*, pp: 448-449.
- Saidam, M., Ramadan, S. & Butler, D. (1995). Upgrading waste stabilization pond effluent by rock filter. *Water Science & Technology*, **31**(12): 369-378.
- Sanchez, A. (1993). Review: Sustainable management of solid wastes and sewage related issues. In T. Carroll-Foster (Ed.), *Agenda 21 - Abstracts, Reviews, and Commentaries*, pp: 149-150. Ottawa, Canada: International Development Research Centre.
- Schellinkhout, A. & Collazos, C. J. (1992). Full-scale application of the USAB technology for sewage treatment. *Water, Science & Technology*, **25** (7): 159-166.
- Scott, J. (1952). *Health and agriculture in China: A fundamental approach to some of the problems of world hunger*. London: Faber and Faber Ltd.
- Sheaffer International LTD. (1998). *An idea whose time has come*. Sheaffer International LTD., Promotional literature.
- Sheaffer, J. (1998). *The modular reclamation and reuse technology: An approach to sustainability*. Sheaffer International LTD., Promotional literature.
- Shelef, G. & Azov, Y. (1996). The coming of era of intensive wastewater reuse in the Mediterranean Region. *Water, Science & Technology*, **33** (10): 115-126.
- Simbeye, E. K. (1980). On-site excreta disposal technologies. Sanitation in developing countries. *Proceedings of the workshop on training*. Lobatse, Botswana. 14-20 August, 1980.
- Sinnatamby, G., Mara, D. & McGarry, M. (1986). Shallow sewers offer hope to slums. *World Water*, **9**(1): 39-41.
- Sinnatamby, G. (1990). Low Cost Sanitation. In J. Hardroy, S. Cairncross and D. Satterthwaite (Eds.), *The poor die young: Housing and health in the third world cities*. London: Earthscan Publications.
- Skillicorn, W., Journey, K. & Spira, P. (1993). *Duckweed aquaculture: A new aquatic farming system for developing countries*. Washington, DC.: World Bank.

- SPORE. (1995). Biogas ignites interest in southern Mali. *Bulletin No. 55*. C.T.A., Wageningen, the Netherlands, p: 5.
- Stille, A. (1998). The Ganges' next life. *New Yorker*. January 19, 1998.
- Strauss, M. & Blumenthal, U. J. (1990). Human waste use in agriculture and aquaculture, utilization practices and health perspectives. IRCWD Report No. 08/09. *Proceedings from international reference centre for waste disposal*. Dübendorf, Switzerland.
- Strauss, M. (1996). Treatment of sludges from non-sewered sanitation system. In A. Balkema, H. Aalbers, and E. Heijndermans (Eds.), *Workshop on sustainable municipal waste water treatment systems*. Leusdan, the Netherlands. ETC in co-operation with WASTE, 12-14 November, 1996.
- Strauss, M., Heinss, U. & Montangero, A. (1998). *Issues in faecal sludge management and project review*. Swiss Federation Institute for Environmental Science and Technology (EAWAG), Water and Sanitation in Developing Countries (SANDEC) and Asian Institute of Technology (AIT).
- Sustainable Strategies. (1998). *Toilets in paradise: Sustainable strategies designs systems for the pacific islands*. Concord, MA.: Sustainable Strategies, newsletter.
- Switzenbaum, M. S. & Jewell, W.J. (1980). Anaerobic attached-film expanded-bed reactor treatment. *Journal Water Pollution Control Federation*, **52**: 1953.
- Tchobanoglous, G., Maitiski, F., Thompson, K. & Chadwick, T. H. (1989). *Research Journal of the Water Pollution Control Federation*, **61** (11/12): 1625-1635.
- Tchobanoglous, G. (1991). Land-based systems, constructed wetlands, and aquatic plant systems in the United States: An overview. In C. Etnier and B. Guterstam (Eds), *Ecological engineering for wastewater treatment*, pp: 110-120. Gothenburg, Sweden: Bokskogen.
- Todd, J. & Todd, N. (1994). *From eco-cities to living machines; principles of ecological design*. Berkely, CA: North Atlantic Books.
- Todd, J. & Josephson, B. (1996). The design of living technologies for waste treatment. *Ecological Engineering*, **6**: 109-136.
- Umar, B. (1996). Biogas - A promising energy supplement for Nigerian economic growth and environment protection. *Energy & Environment*, **7** (3): 309-315.
- United Nations Conference on Environment and Development (UNCED). (1992). *Agenda 21: Programme of action for sustainable development*. Rio de Janeiro, Brazil. 3-14 June 1992.
- United Nations Development Program (UNDP). (1994). *Electricity, fuel, and fertiliser from municipal and industrial organic waste in Tanzania: a biogas plant for Africa*. Project Document: URT/93/G31/A/1G/99.
- United Nations Development Program (UNDP). (1996). *Urban agriculture: food, jobs and sustainable cities*. New York: UNDP.
- United Nations Environmental Programme (UNEP). (1984). *Energy storage systems in developing countries*. Nairobi, Kenya: UNEP.
- United States Environmental Protection Agency of International Development (U.S.E.P.A.). (1992). *Manual of guidelines for water reuse*. Environmental Protection Agency/625/R-92/004.

- United Nations (UN). (1997). *Critical Trends: Global Change and Sustainable Development*. New York.
- van Buuren, J. (1996). Anaerobic wastewater treatment in developing countries, a sustainable core technology. In A. Balkema, H. Aalbers and E. Heijndermans (Eds.), *Workshop on sustainable municipal waste water treatment systems*, pp: 140-153. Leusdan, the Netherlands. ETC in co-operation with WASTE. 12-14 November, 1996.
- Veenestra, S. & Alaerts, G. (1996). Technology selection for pollution control. In A. Balkema, H. Aalbers and E. Heijndermans (Eds.), *Workshop on sustainable municipal waste water treatment systems*: pp: 17-40. Leusdan, the Netherlands. ETC in co-operation with WASTE. 12-14 November, 1996.
- Wang, R., Yan, J., Lu, B. & Hu, D. (1998). The Practice of integrated bio-Systems in China. In E. L. Foo and T. Della Senta (Eds.), *Internet conference on integrated bio-systems (ICIBS)*, pp: 1-11. Available: <http://home2.swipnet.se/~w-25860/icibs/wang/>.
- WEF (Water Environment Federation). (1995). Greenhouse filter system yields zero discharge. *Water Environment and Technology*, June, 1995.
- Weisner, S. E. B., Eriksson, W., Graneli, W. & Leonardson, L. (1994). Influence of macrophytes on nitrate removal in wetlands. *Ambio*, 23 (6): 363-366.
- Winblad, U. & Kilama, W. (1995). *Sanitation without water*. Macmillan Education Ltd.
- Witter, E. & Lopez-Real, J. M. (1987). The potential of sewage sludge and composting in a nitrogen recycling strategy for agriculture. *Biological Agriculture and Horticulture*, 5.
- Sanio, M., Burack, D. and Siddiqui, S. (1998). *Reuse of urban waste for agriculture*. World Engineering Partnership for Sustainable Development. Alexandria, VA, USA.
- World Health Organization (WHO). (1987). *Wastewater stabilization ponds: Principles of planning and practice*. WHO EMRO Technical Publication No. 10. Regional Office for the Eastern Mediterranean, Alexandria.
- World Health Organization (WHO). (1989). *Health guidelines for the use of wastewater in agriculture and aquaculture: Report of a WHO scientific group* (Technical Report Series No. 778). Geneva, Switzerland: WHO.
- World Resource Institute, UNEP, UNDP & World Bank. (1996). *World resources: 1996-1997*. New York: Oxford University Press.
- Wu, Y. & Lui, K. (1988). An introduction to the state of research and development of biogas in rural areas of China in recent years and discussion on improvement of old biogas technology (Chinese). *Biogas technology and utilisation research*. Chengdu Biological Science Research Institute, pp: 1-13.
- Yan, J. & Ma, S. (1991). The function of ecological engineering in environmental conservation with some case studies from China. In C. Etnier and B. Guterstam (Eds.), *Ecological engineering for wastewater treatment*, pp: 110-120. Gothenburg, Sweden: Bokskogen.
- Yanez, F. A. & Pescod, M. B. (1988). Wastewater treatment and reuse in Jordan. *Mission report to UNDP/World Bank integrated resource recovery project*. Washington, D. C.
- Yang, P. Y., Chen, H. & Ma, T. (1994). Development of a land limited wastewater treatment plant for small and rural communities in the tropics. *Water, Science & Technology*, 29 (12): 1-12.
- Yu, H., Tay, J. & Wilson, F. (1997). A sustainable municipal wastewater treatment process for tropical and subtropical regions in developing countries. *Water, Science & Technology*, 35 (9): 191-198.

- Zandstra, I. (1986). *Reclamation of nutrients, water and energy from wastes: A review of selected IDRC-supported research*. (Manuscript Report No. IDRC-MR124e). Ottawa: International Development Research Centre.
- Zhao, Q. & Wang, B.(1996). Evaluation on a pilot-scale attached-growth pond system treating domestic wastewater. *Water Resource*, **30**: 242-245.
- Zhenbim, W., Yicheng, X., Jiaqi, D., Qijun, Z &Xitao, C. Studies on wastewater treatment by means of integrated biological pond system: design and function of macrophytes. *Water Science and Technology*, **27** (1): 97-105.
- Zhongxiang, Z. & Yi, Q. (1991). Water saving and wastewater reuse in China and recycle in China. *Water, Science & Technology*, **23** (10-12): 2135-2140.
- Zirschikly, J. & Reed, S. (1988). The use of duckweed for wastewater treatment. *Journal Water Pollution Control Federation*, **60**: 1253-1258.

Annex I - Internet Resources

Zero Emissions Research Initiative - United Nations University

http://www.ias.unu.edu/research_prog/unuzeri/Default.html

- ? The United Nations University's Zero Emissions Research Initiative (UNU/ZERI) is a project to promote the realization of sustainable industry and society through Zero Emissions. Zero Emissions is a set of concepts with which to redesign human activities to achieve maximum productivity with minimal waste, while improving economic feasibility.

Information and Advisory Service on Appropriate Technology (ISAT) - BIOGAS

http://gate.gtz.de/biogas/AT_biogas.html

- ? Biogas plants constitute a widely disseminated branch of technology that came into use more than 30 years ago in developing countries.

Swiss Centre for Development Cooperation in Technology and Management

<http://www.skat.ch/textonly/index.htm>

- ? The team of SKAT sector professionals adopts balanced approaches to strive for sustainable technologies, not only in terms of hardware, but also in terms of supporting "software".

Water and Sanitation in Developing Countries (SANDEC)

<http://www.sandec.ch/>

- ? SANDEC is the Department of Water and Sanitation in Developing Countries at the Swiss Federal Institute for Environmental Science and Technology (EAWAG) in Dübendorf, Switzerland. Its mandate is to assist in developing appropriate and sustainable water and sanitation concepts and technologies adapted to the different physical and socio-economic conditions prevailing in developing countries.

Sustainable Strategies - Ecological Engineering

<http://www.ecological-engineering.com/>

- ? Pollution avoidance, waste management, ecology, sanitation, ecological engineering, water conservation, sustainable, public health, zero discharge, green technology, alternative wastewater treatment.

Global Applied Research Network (GARNET)

<http://info.lut.ac.uk/departments/cv/wedc/garnet/grntover.html>

- ? GARNET is a mechanism for information exchange in the water supply and sanitation sector using low-cost, informal networks of researchers, practitioners and funders of research

Water Supply and Sanitation Collaborative Council

<http://www.wsscc.org/index.html>

- ? The Water Supply and Sanitation Collaborative Council was established in 1990 at the end of the International Drinking Water Supply and Sanitation Decade.

The UNDP-World Bank Water and Sanitation Program

<http://www.wsp.org/English/index.html>

International Development Research Centre
Annex II - Reviewed Projects in Waste Management (1974 - 1997)

HW = Domestic Human Waste and Wastewater Treatment/recovery.....	30 projects
DSW = Domestic Solid Waste Treatment/recovery.....	12 projects
AGW = Agro-based Waste and Wastewater Treatment/recovery.....	25 projects
IW = Industrial Waste and Wastewater Treatment.....	26 projects
NW = Water and Sanitation Information Networks.....	20 projects

Project Number	Project Name	Focus
740021	Alternative Waste Disposal Methods (Tanzania) - Phase I	HW
750007	Stabilisation Ponds, (Peru)	HW
750125	Squatter Settlement Sanitation (Botswana) - Phase I	HW
750129	Disposal of Human Excreta in Rural Areas (Ghana)	HW
760074	By-Products (Egypt) - Phase I	AGW
760140	Wastewater Reclamation, (Malaysia, Thailand, Israel, Kenya, Peru)	HW
760141	Piggery Waste Treatment, (Singapore) - Phase I	AGW
760156	Waste Disposal: State of the Art Review, (Global)	NW
760175	Urban Services Management (Korea)	SW
770059	Waste Reclamation, (Thailand)	HW
770103	Wastes Reuse (Korea)	HW
780010	Information Centre on Sanitation (Asia) - Phase I	NW
780014	Palm Oil Wastes (Malaysia)	AGW
780015	Excreta Reuse (Guatemala)	HW
780017	Self-Help Sanitation (Mozambique)	HW
780028	Sanitation Technology (Zambia)	HW
780029	Alternative Waste Disposal Methods (Tanzania) - Phase II	HW
780097	Waste Management (Thailand)	HW
790047	Animal Production Systems (CATIE) - Phase II	AGW
790071	Piggery Waste Treatment (Singapore) - Phase II	AGW
790072	Pathogen Transfer/Wastewater, (Israel)	HW
790137	Lignocellulolytic Fungi (Thailand) - Phase I	AGW

790164	Squatter Settlement Sanitation (Botswana) - Phase II	HW
800006	By-Products (Egypt) - Phase II	AGW
800177	Upgrading Sanitation (India)	HW
800198	Solid Wastes (Honduras)	SW
810151	Urban Waste Management (Korea)	SW
820135	Livestock Feeding Systems (Philippines)	AGW
820160	Rural Sanitation Research (Kenya)	HW
820072	Environmental Sanitation Information Centre (ENSIC) - Phase II	NW
821016	Study of Jamaican Bauxite Waste	IW
830031	Hospital Wastewater, (Thailand)	IW
830110	By-Products (Sudan) - Phase II	AGW
830152	REPIDISCA - Consolidation Phase - Phase III	NW
830156	Piggery Waste Treatment (Malaysia)	AGW
830290	Low-Cost Urban Sanitation (Mozambique)	HW
831018	Aggregate Tailings Slime (Singapore)	IW
841030	Fly-Ash Concrete (Argentina)	IW
841032	Activated Carbon (Colombia)	IW
830230	Training Program on Integrated Fish Farming (China) - Phase I	NW
840245	BLISS Waste Treatment, (Philippines)	HW
850037	Solid Waste Management (Peru)	SW
850048	Waste Management Training (Singapore)	NW
850203	Wastewater Reuse, (Peru)	HW
850239	Agricultural Waste Management Information (Malaysia)	NW
851015	Blast Furnace Slag (Argentina)	IW
851016	Biogas Refrigerator (China)	IW
851038	Industrial Wastewater Treatment Biogas, (India)	IW
860009	Evaluation of DAFF Latrines (Guatemala) - Phase I	HW
860098	Wood Utilization (China)	IW
860106	Approtech Asia Information System on Water and Sanitation - Phase I	NW
860109	African Water and Sanitation Information System (CIEH) - Phase I	NW

860132	Windpump and Composting Latrine Technology (Panama)	HW
860321	REPIDISCA (Guatemala)	NW
861039	Bauxite Waste Bricks (Jamaica)	IW
861040	Industrial Waste Exchange (Philippines) - Phase I	IW
861044	Multilayer Polyethylene Films (Jordan) - Phase I	IW
870003	Regional Training Course on Advanced Biogas Reactor	IW
870013	Palmwood Utilization (Asia)	AGW
870086	Human Pathogen Survival (Zaire)	HW
870235	Integrated Livestock/Aquaculture (Cameroon)	AGW
870258	Muscovy Ducks (Thailand) - Phase I	AGW
870286	DAFF Latrine (Guatemala) - Phase II	HW
871024	Sugar Cane Waste Utilization (Cuba) - Phase I	AGW
871046	Slurry Pond Reclamation, (Malaysia)	IW
880001	Women, Water and Sanitation: An Action Research Project, (Egypt)	NW
880007	Fish Nutrition (AIT) - Phase	AGW
880104	Integral System for Recycling Organic Waste (Mexico)	HW
880108	By-Products Network (ILCA) - Phase II	NW
880222	Soil Fertility (Tanzania)	AGW
880275	Agro-based Wastewater (Thailand)	AGW
890012	By-Products (Nigeria) - Phase II	AGW
890080	Water and Sanitation Information Network (Tanzania) (MAJIDOC)	NW
890171	Peri-Urban Sanitation (Lesotho)	HW
890211	Gravel Water Filtration Systems (Jordan)	HW
890212	Approtech Asia Information System on Water and Sanitation - Phase II	NW
900027	African Water and Sanitation Information System (CIEH) - Phase II	NW
900048	Management of Solid Wastes in Ecuador	SW
900153	Urban Domestic Wastewater Treatment (Senegal)	HW
900163	Leather Industry (Uruguay)	IW
901005	Recycled Polyethylene Waste Film Application (Egypt)	IW
901031	Multilayer Polyethylene Film (Jordan) - Phase II	IW

910016	Livestock Wastes (Korea) - Phase II	AGW
910077	School Chalk (Tanzania)	IW
910218	Duck-Fish Integration (Thailand) - Phase II	AGW
910226	Biogas Refrigerator Production Technology	IW
910245	Alternatives for Solid Waste Management	SW
911015	Use of Fly Ash in Cement (India)	IW
920017	Solid Waste Management (Morocco)	SW
921008	Biosorbents: Use of One Waste Product to Clean Up Another (China)	IW
928601	Wastewaters from Olive Oil Mills, (Jordan)	AGW
928602	Date Palm Mid-Rib Utilization, Egypt	AGW
930025	Waste Utilization for Urban Agriculture (Uganda)	SW
930037	Urban Agriculture in Dar es Salaam, Tanzania	DSW
931003	Land Restoration Through Waste Management (UWO / India)	IW
931007	Cashew Apple Valorization (Viet Nam / Canada)	AGW
931010	Sugar Cane Waste Utilization (Cuba) - Phase II	AGW
931550	Latin America Urban Water Management Network	NW
938010	Waste Minimization and Pollution Control for Small and Medium Enterprises (Philippines) - Phase II	IW
938012	Effects of Sewage Utilization on Fish Farming and Irrigation, Hanoi, Vietnam	HW
940012	Engineered Wetlands for Urban Water Management, Battambang, Cambodia	HW
941005	Scrap Tires for Earthworks (Brazil)	IW
944076	Solid Waste Management Project - Video	NW
948016	Pollution Prevention Technology Centre for Small, Medium and Micro-Enterprises (Indonesia)	IW
948307	Community Based Solid Waste Management in Slums (India)	SW
950012	Urban Agriculture for Sanitation and Income Generation, Metro Fortaleza, Brazil	SW
950024	Urban Agriculture in Local Waste Management: Santiago, Dominican Republic	SW
958604	Biotransformation, Morocco	AGW
958768	Environmentally Sound Industrial Technologies in Latin America: Transfer and Diffusion	NW

960035	Urban Horticultural Technologies, Port-au-Prince (Haiti)	SW
960220	Disposal of the Waste Accompanying Masilah Oil, (Yemen)	IWW
960900	United Nations Univeristy - waste and wastewater related information	NW
965605	Integrated Water Supply and Wastewater Treatment for Rural Egyptian Communities	HW
968531	Phosphate Rock Blends (Zimbabwe) II	IW
970205	Environment and Public Health (Israel/Palestine)	NW

International Development Research Centre
Annex III - Technological Advances Identified in IDRC Project Review

Project	Project Name
78-0097	Waste Management, Thailand
88-0104	SIRDO - Organic Waste Recycling, Mexico
89-0211	Gravel Water Filtration System, Jordan
90-0153	Urban Domestic Wastewater Treatment, Senegal
92-8601	Wastewater from Olive Mills, Jordan
93-8012	The Effects of Sewage Utilisation on Fish Farming and Irrigation, Vietnam
94-0012	Engineered Wetlands for Urban Water Management, Cambodia

Review of Projects:

Centre file: 78-0097 (Waste Management, Thailand):

The most notable development derived from this research was an Upflow Anaerobic Filter (UAF) as an alternative to soak away septic tanks and space intensive septic leaching field. The UAF that was developed required no mechanical equipment and operation and maintenance were apparently simple. This is a potentially viable technology today in urban areas and its post-development impacts should be further explored. Based on the installation of the systems (sub-surface or above ground) it could be integrated into confined space neighbourhoods and service multiple households based on its design. The combined septic tank-UAF system was determined to be effective in removing microorganisms, particularly helminthic ova and bacteria from wastewater effluent. Currently, the septic tank-anaerobic upflow filter system is being used extensively in Thailand (personal correspondence: Polprasert, 1998). The system is being used in newly constructed housing units that do not have access to central treatment plants. There are now several companies in Thailand and in the region that have commercialised this treatment system and now manufacture and distribute it. It is not apparent at this time to what extent the SIRDO has been implemented.

Centre file 88-0104 (SIRDO - Organic Waste Recycling, Mexico):

The technical merits and overall efficiency of the SIRDO system are well documented. This system is, from most accounts, effective in the treatment, recovery and reuse of domestic human waste, organic kitchen and yard waste for use in the production of agricultural goods. The opportunity to recover the operation and maintenance costs through the sale of marketable compost and horticultural goods add significant value to the viability and long-term sustainability of SIRDO. Unfortunately, the SIRDO system met resistance from within certain factions at the community and institutional levels, leading to a reduction in its popularity. These events became a major impediment to its widespread replication.

Centre file: 89-0211 (Gravel Water Filtration System, Jordan):

The main advantages of this system are its reliability, ease of operation and low maintenance costs. The gravel and filtration media is derived from local wadi and is therefore readily available and inexpensive. In addition to upgrading WSP effluent, variations of this system could be utilised on a small scale for urban wastewater treatment and also in combination with demand-accurate irrigation technologies such as *closed-conduit systems* (sprinkler, micro-sprinkler and drip irrigation) where suspended solids and algae need to be at minimum to prevent clogging of the pressurised system (Hillel, 1987; Bartone, 1991). In the Middle East and other arid and semi-arid regions, the combination of low-cost WSP treatment, effluent upgrading systems, such as the rock and gravel filter system and demand-accurate irrigation systems should be further studied for combination with urban and peri-urban agricultural production.

Centre file: 90-0153 (Urban Domestic Wastewater Treatment, Senegal):

In Castor, the local NGO, ENDA-Tiers Monde, has built a wastewater collection and treatment system serving most of the communities inhabitants. The system consists of a grease trap, two septic tanks, followed by a small-bore sewage system. The sewage enters a large decanting tank/sedimentation basin, that gets covered by a sludge blanket where most of the sludge is retained. From this point, the secondary effluent flows to a series of 4 aerobic concrete tanks. The tanks are approximately 1 metre. deep and are narrowly designed to prevent wind from layering the plants to one side of the ponds. Water hyacinth/water lettuce (*pistia stratiotes*) comprise the active wastewater treatment at this point in the process. Long-term sustainability and replication of this system seems inevitable as several neighbouring communities have expressed their interest in implementing similar systems. Women and children are very active in the production, harvest and composting of the water hyacinth for the production of a rich humus. Natural wastewater treatment through ecological engineering, similar to the project described above, offer low-cost solutions to modern waste management. These systems are versatile, low-cost and can be implemented with local construction supplies and human resources. Most importantly, these systems are capable of recovering and marketing organic waste for use in complementary processes such as agriculture and thus able to recovery construction, operation and maintenance cost of the system.

Centre file: 92-8601 (Wastewater from Olive Mills, Jordan):

The UASB technology is a viable technology for hot, arid regions such as the Middle East and can be effectively implemented in the treatment of wastes with extremely high BOD. This approach can increase the wastewater quality to an acceptable standards and allows for its discharge into municipal sewerage systems. Combining this technology with aerobic lagoons offers a high level of treatment for wastewater and sludge. Opportunities exist to reclaim these treated wastes as opposed to disposing of them, for use in agricultural production. In addition, the continued support in the development of low-cost, on-site alternatives for the treatment of industrial wastes is essential to the protection of existing surface and ground water supplies in the developing world. Facilitating, low-cost, industrial waste treatment to, at least, secondary standards prior to discharge, or totally separating combined domestic and industrial waste treatment, will enable incremental measures to utilise the less toxic domestic waste stream in a variety of agricultural production and landscape irrigation schemes.

Centre file 93-8012: The Effects of Sewage Utilisation on Fish Farming & Irrigation, Hanoi

This project determined that the use of untreated wastewater has had consequences in terms of both human and environmental health. Industrial contamination of the wastewater effluent was seen as a major problem when its utilisation was considered for aquaculture and irrigation. Water hyacinth grown on the untreated wastewater was determined to accumulated heavy metals. Therefore, it is suggested that the hyacinth should not be used as a food for swine. Fish cultivated in sewage-fed ponds also accumulated heavy metals as did the soil irrigated with wastewater. As late as 1998, there was a pervasive scepticism among Hanoi residents regarding the quality of fish products derived from Thanh Tri district. It is also rumoured that a Japanese funded drainage project has increased the scope of the problem to the point that nobody know what is being discharged into the system (anonymous personal communication - VNU, 1998).

The principle investigator suggests two methods to mitigate these dangers: i) industrial pre-treatment to remove the toxic constituents and/or ii) a series of ponds with water hyacinths pre-treating the industrial waste that would eventually feed into secondary ponds for aquaculture. It was suggested that an incremental approach to upgrading the quality of the wetlands was necessary it would be the only economically feasible choice. Treatment of all effluent sources (domestic and industrial) or building a centralised treatment facility was not seen as a feasible option. The author also stated that support was needed by the local and provincial governments and international funding agencies in order to successfully implement a scheme to upgrade the wastewater reuse scheme to protect ecosystem health.

These findings, at the very least, suggest the need to strengthen the ability of municipal governments and industries to develop low-cost alternatives for on-site industrial wastewater pre-treatment. Ideally, additional research funding would be directed toward municipal innovations that would enable the complete separation of the human domestic sewerage collection systems and the industrial collection systems. Approaches must be developed to plan and implement cost effective solutions to minimising the discharge of toxic industrial effluents into productive natural wetland resource areas such as Thanh Tri district.

Centre file: 94-0012 (Engineered Wetlands for Urban Water Management, Cambodia):

This project focused on pollution control and urban wastewater management using the Chamkar Samroung Sewage Water Treatment Plant as a training and demonstration facility. This project determined that engineered wetlands are a feasible technological alternative to conventional treatment approaches. Several variations of wetlands used for wastewater treatment exist and researchers continue to collect data on the feasibility of these systems for domestic wastewater treatment. The project supported multi-disciplinary data collection, and supported efforts to create linkages between wastewater reuse for irrigation and production of food for low-income communities. The project was of multi-disciplinary nature and aimed to improve the environmental health and socioeconomic development of an urban setting.

The project was designed to capture research on biological, economic, and social aspects of using wetlands as tertiary treatment facilities. It also promoted research associated with the development of low-cost and appropriate technologies that may be replicable and transferable to other settings. IDRC involvement in the project focused on institutional capacity building and socioeconomic and technical research aspects.

Results from this project strongly suggests that engineered wetlands are a feasible technological alternative to conventional treatment approaches. Unfortunately, this specific project, appeared to fail not due to limitations of the technology, but from the inability to promote broad-level organisation and support from both ground-level community agents, as well as governmental institutions at all levels.

Annex IV: Report Contacts

United Nations University/Project "Zero Emissions Research Initiative"

The recent conference on Integrated bio-systems jointly organised by the Institute of Advanced Studies (IAS) of the United Nations University (UNU-Tokyo) and the UNESCO Microbial Resource Centre at Stockholm, as an activity of the UNU/Project "Zero Emissions Research Initiative" focused on the recovery and reuse of biological waste.

(see report section 8.0 - Integrated Recovery)

Contact:

Jacky Foo

E-mail: foo@swipnet.se

http://www.ias.unu.edu/research_prog/unuzeri/Default.html

Sustainable Strategies

Contact:

David Del Porto

152 Commonwealth Avenue

Concord, Massachusetts 01742-2943

Tel.: 978/369-9440

Fax: 508/369-2484

sustainable@aics.net

www.ecological-engineering.com

(see report section 9.2 - Composting Toilets)

GreenGold Corporation

Contact:

Paul Skillicorn or Dr. William M. Spira

<http://www.ntrnet.net/~skilli/bsum98i.htm>

Email: skilli@ntrnet.net

13012 Herald Circle

Apple Valley, MN 55124

(612) 891-2360

(see report section 10.5 - GreenGold)

PRISM-Bangladesh

Contact:

Mr Mohammed Ikramullah,?

House # 49, Road # 4A

Dhanmondi R/A

Dhaka-1205, Bangladesh

E-mail: prismbd@citechco.net

Tel: (O): +880-2-9663544, 861170; Fax: +880-2-9663533

(see report section 10.4 - PRISM-Bangladesh)

Modular Reclamation Reuse System Technology

Contact:

Jack Shaeffer
Sheaffer International Limited
Chicago, IL
630.548.1980

(see report section 10.8.3 Modular Reclamation Systems)

Environmental Design and Management Ltd.

Contact:

Margo and Ross Cantwell
Halifax, NS, B3J 3N2
(902)425-7900
fax (902)425-7990
email: info@edm.ca

(see report section 8.2 Advanced Solar Aquatics)

World Engineering Partnership for Sustainable Development

Secretariat for Recycling Waste for Agriculture: The Rural - Urban Connection
1420 King Street, 3rd floor, Alexandria VA, USA 22314
Tel: (703) 684-2893, Fax: (703) 836-4875
Email: msanio@igc.org, website: www.wenet.org

Contact:

Mr. Mike Sanio
Email: msanio@igc.org